

Energom-PD3000 PARTIAL DISCHARGE MONITOR

SWITCHGEAR PROTECTION RELAY



Introduction

Partial discharge is a kind of pulse discharge, which will produce a series of physical phenomena and chemical changes such as light, sound, electrical and mechanical vibration in the interior and surrounding space of power equipment. When insulation defects appear inside high-voltage electrical equipment, it will be accompanied by the generation of partial discharge signals.

Energom-PD3000 partial discharge monitor can be used with UHF sensor, TEV sensor, Ultrasonic sensor and online detection of partial discharge of high voltage equipment such as transformers, high voltage switchgear, GIS, and cable joints. Easy to carry, fast measurement, strong anti-interference ability, easy to use on site.

Working Principle

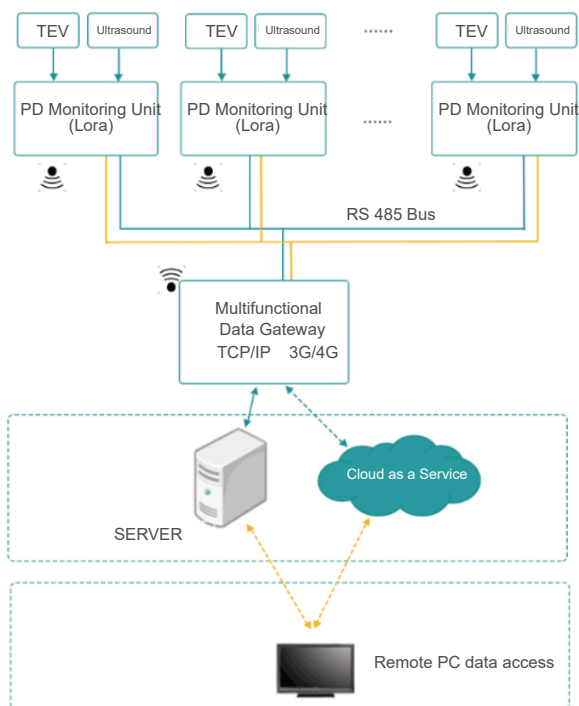

Main Features

- Wall-mounted installation.
- Alarm multi-level threshold setting.
- Waveform data recording function.
- RS 485, Modbus-RTU, SCADA systems.
- Sensor detects TEV and audible ultrasonic.
- Automatic PD data acquisition and analysis.
- 2*DO NC & NO contact for external alarm trig.
- Anti-interference performance and high measurement accuracy.
- Joint detection of partial discharge signals by transient earth waves.
- HMI supports max 96pcs sensor, optional wireless, and wired(RS485) connection.

Wiring Method

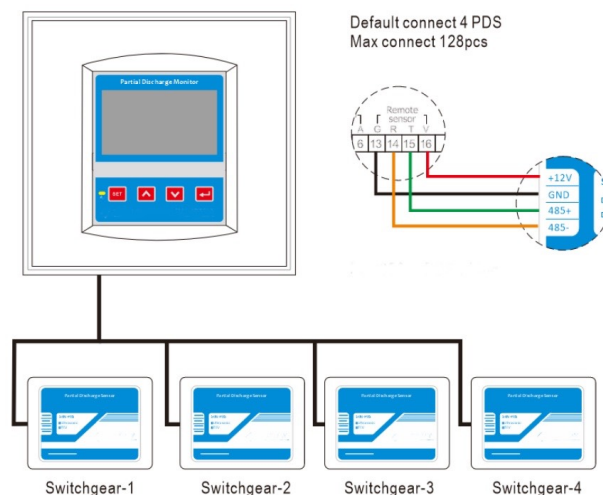

Technical Characteristics

HMI electrical specification	
Auxiliary power	85-265Vac/dc, 20-60Vdc Optional
Power consumption	<6W
Communication	RS-485, MODBUS-RTU
Digital output	2* NC & NO, passive node
Environment temperature	-10 ~ +60°C
Environment humidity	RH 20% ~ 95% (No condensation)
Dimensions (L × W × H)	96*96*85mm or 144*144*100mm
Open install hole	91*91mm or 138*138mm
Remote sensor	
Power supply	12Vdc or 2000mAh build in battery*
Wireless band	433MHz~2.4GHz optional
Signal transmission distance	Up to 80m (260 feet)
Static power consumption	<10mW
Installation method	4* strong magnet, wall mount
TEV sensor	
Detect range	0~60 dBmV
HF frequency response	3~100MHz
Resolution / Accuracy	1dBmV / ±1dBmV
Ultrasonic sensor	
Detect range	-7dBμV~68dBμV
Resolution / Accuracy	1dB / ±1dB
Sensitivity	-65 dB (0 dB=1 volt/μbar rms SPL)
Sensor center frequency	40 KHz