



# TEMPERATURE AND HUMIDITY TRANSDUCER P18D TYPE



USER'S MANUAL





# CONTENTS

<b>1. APPLICATION</b>	<b>5</b>
<b>2. TRANSDUCER SET</b>	<b>5</b>
<b>3. BASIC REQUIREMENTS, OPERATIONAL SAFETY</b>	<b>5</b>
<b>4. INSTALLATION</b>	<b>6</b>
4.1. Assembly	6
4.2. Electrical Connections	7
<b>5. SERVICING</b>	<b>9</b>
5.1. Messages after supply switching on	9
5.2. Description of P18D display	10
5.3. Function of capacitive button	11
5.4. Function of the P18D transducer	11
5.4.1. Measured and calculated values	12
5.4.2. Chosen of values for analog outputs	13
5.4.3. Individual characteristic of analog outputs	13
5.4.4. Default parameters	15
<b>6. RS-485 interface</b>	<b>16</b>
6.1. Serial interface connection	16
6.2. Description of the Modbus Protocol Implementation	17
6.3. Description of the Modbus functions	17
6.4. Register map	20
6.5. Register for write or readout	21
6.6. Register only for readout	24
6.7. Emergency restoration of default parameters	26
<b>7. ACCESSORIES</b>	<b>27</b>
<b>8. TECHNICAL DATA</b>	<b>28</b>
<b>9. ORDERING CODES</b>	<b>30</b>
<b>10. MAINTENANCE AND GUARANTEE</b>	<b>31</b>



# 1. APPLICATION

The P18D transducer is a device destined for the continuous measurement and conversion of relative humidity and ambient temperature into a digital form and into a voltage or current standard signal. The transducer is fixed on a wall. The programming of the transducer is possible by means of the RS-485 interface. The transducer configuration can be carried out by the free LPCon program available on our website [www.lumel.com.pl/en/](http://www.lumel.com.pl/en/).

Applied sensor shields enable the application of the P18D transducer in various ambient conditions

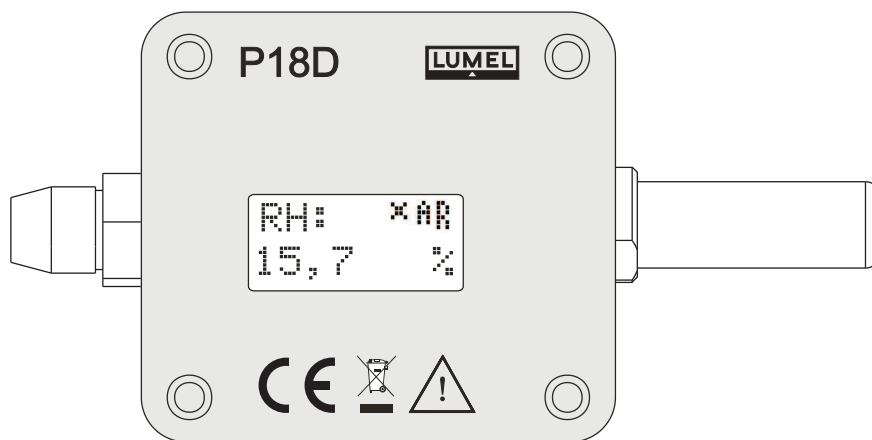

*Fig.1. View of the P18D transducer.*

## 2. TRANSDUCER SET

- 1. transducer P18D..... 1 pc
- 2. service manual..... 1 pc
- 3. guarantee card..... 1 pc

## 3. BASIC REQUIREMENTS, OPERATIONAL SAFETY

In the security scope, the transducer meets the requirements of the EN 61010 -1 standard.

### Remarks Concerning the Operator Safety:

#### 1. General

- All operations concerning transport, installation, and commissioning as well as maintenance must be carried out by qualified, skilled personnel



- Before switching the transducer on, one must check the correctness of connections to the network.
- The device is destined to be installed and used in industrial electro-magnetic environment conditions.

## 4. INSTALLATION

### 4.1. Assembly

The P18D transducer is designed to be mounted on a wall by means of a screw connection or glue without the loss of IP65 tightness. The transducer housing is made of a self-extinguishing plastics. The transducer has screw connectors placed inside the transducer, which enable the connection of external wires of 1 mm<sup>2</sup> cross-section.

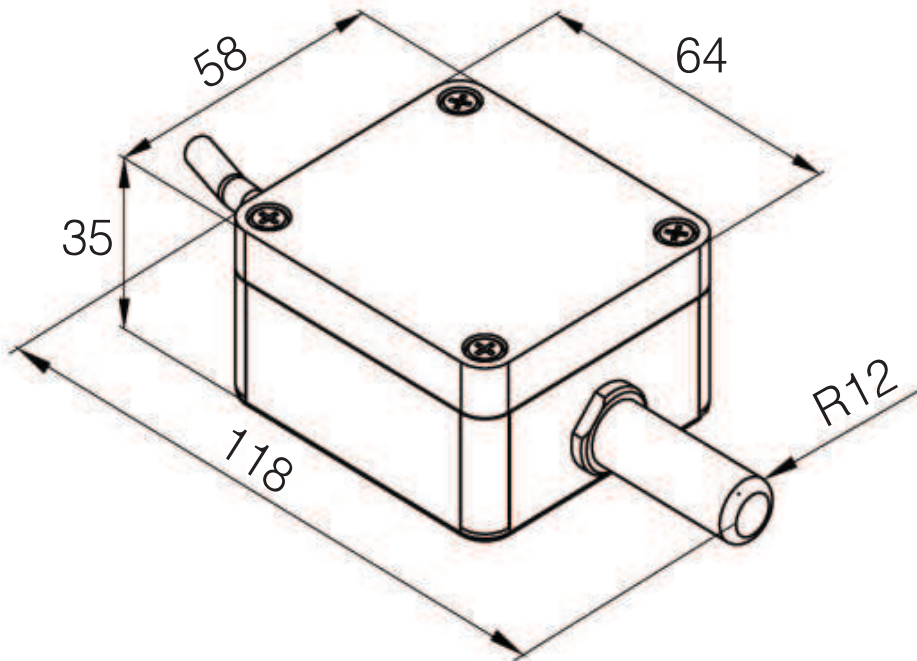

*Fig.2. Overall Dimensions of the P18D Transducer*

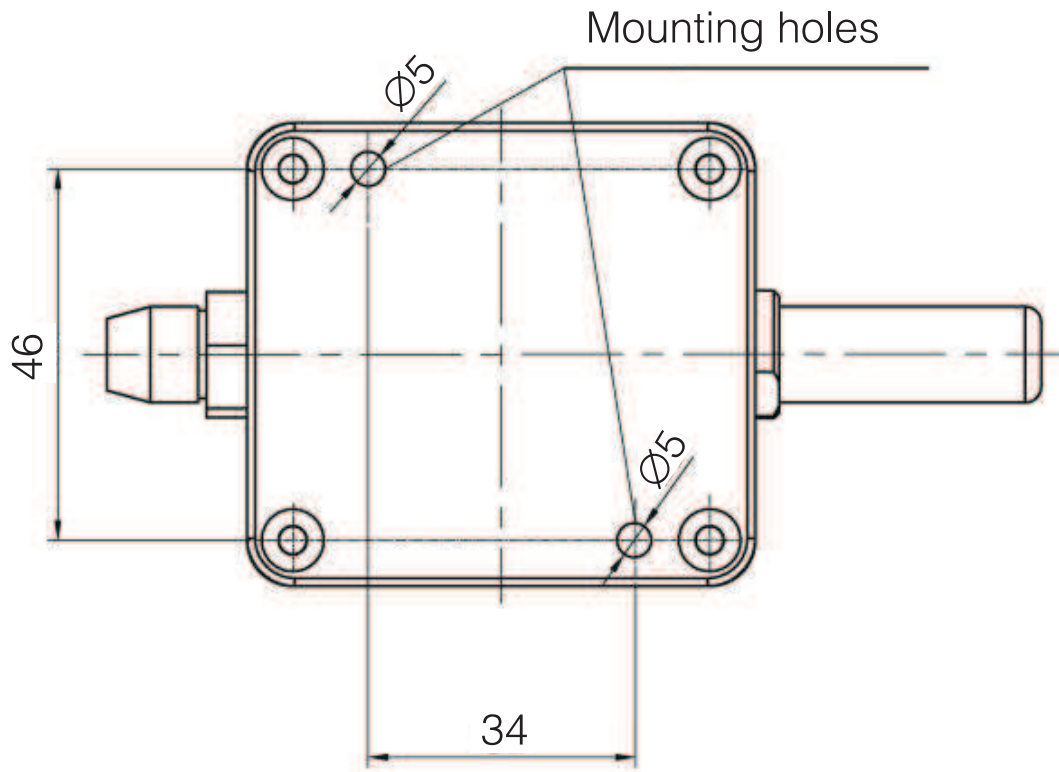

*Fig.3. Lay-out of Assembly Holes of the P18D Transducer*

## 4.2. Electrical Connections

The P18D transducer has 8 connecting terminals to which there is access after removing the cover of the transducer housing.

For electrical connections, one must use a round wire with external diameter from 3.5 mm up to 6 mm.

Before the transducer assembly, one must remove the LCD display, pass supplying wires through the packing. Twist the packing seal in order to obtain the leaktightness. If the packing seal is not twisted, we cannot ensure the required IP 65 leaktightness. After screwing the wires to the terminal, the LCD display should be put back.

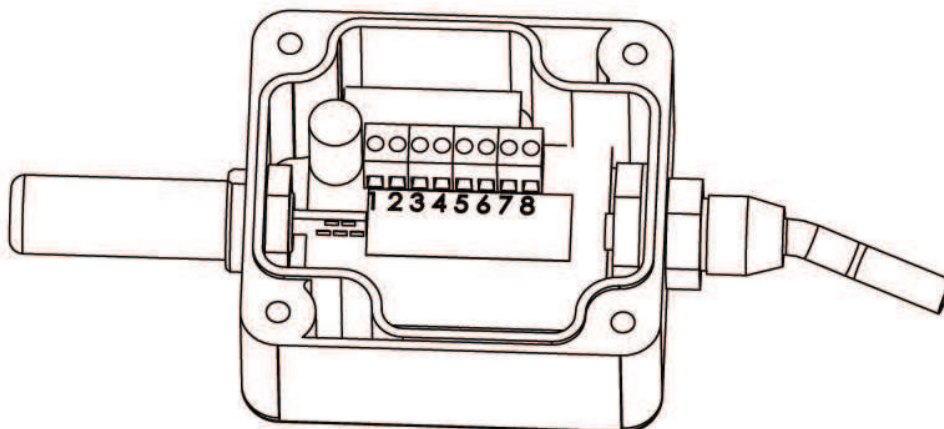

*Fig.4. Marking of Terminals for the Connection of External Signals*

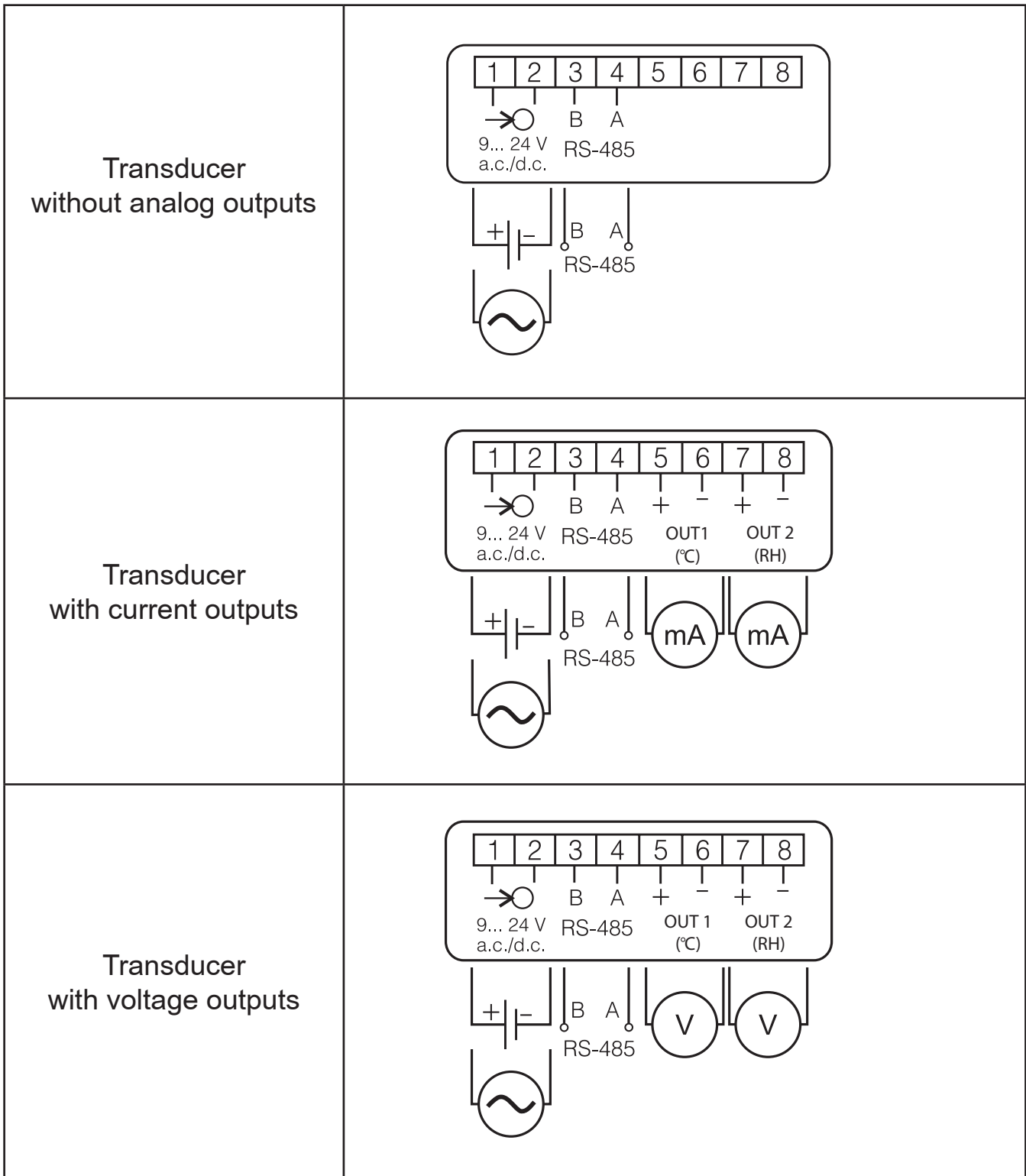

*Fig. 5. Way of Electrical Signal Connection*

To connect the input signals in an environment with high interference, one must apply shielded wires. The shield must be connected to the nearest PE point from the feeder side.



## 5. SERVICING

The transmitter is equipped with a 8x2 characters display field with backlight and one capacitive button located on the transmitter housing. After connecting wires, closing and servicing the housing, and connecting to the supply, the transducer is ready to work with manufacturer's settings (table 8).

The transducer can be programmed through the RS-485 interface.

One can program following parameters in the transducer:

- communication parameters
- averaging time of the measurement,
- individual characteristics of analog outputs  
(for executions with analog outputs).

There is the possibility to connect the transducer through another transmission media, like: **ETHERNET, USB**, using LUMEL S.A.'s converters.

### 5.1. Messages after supply switching on

After connecting external signals and switching the supply on, the transducer displays the type, the current software version, serial number and set the communication parameters (address, baud rate and mode). After about 5 seconds, the transducer automatically switches to the mode in which it measures and converts into the analog output signal. The transducer displays the measured value with the unit on the bottom row of the display, on the top row of the display contains information about the type of displayed value and pictograms: of transmission on RS-485 link, the mode of presentation of the measured value and the ratio of the measured value read from the sensor.

## 5.2. Description of P18D display

Readout field in the transducer P18D is backlite character LCD. The backlight is lit after turning on the power and the capacitive button is pressed on the case. The backlight is turned off automatically after 30 seconds of inactivity time.

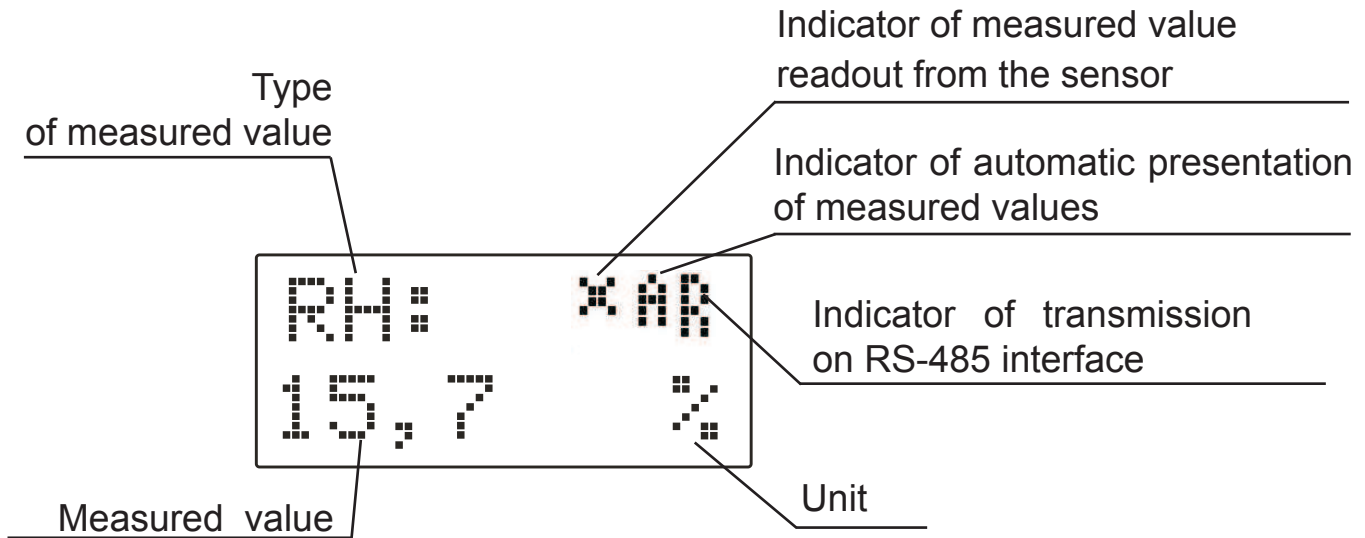

*Fig.6 Description of P18D transducer readout field.*

The displayed symbols are shown in the table 1.

Table 1

Symbol	Description
T:	Type of displayed value in the lower line of LCD - temperature
RH:	Type of displayed value in the lower line of LCD – relative humidity
DP:	Type of displayed value in the lower line of LCD – dew point
AH:	Type of displayed value in the lower line of LCD – absolute humidity
*	Readout ratio of measured value from the sensor
A	Automatic mode of measured values presentation – type of displayed value is automatically switched every 3 seconds in following order: temperature → realtive humidity → dew point → absolute humidity → temperature ...
H	Indicator of data receive on the RS-485 interface
T	Indicator of data transmission on the RS-485 interface

### 5.3. Functions of capacitive button

The P18D transducers have one capacitive button on the housing. The position of the button is shown on the fig.7.

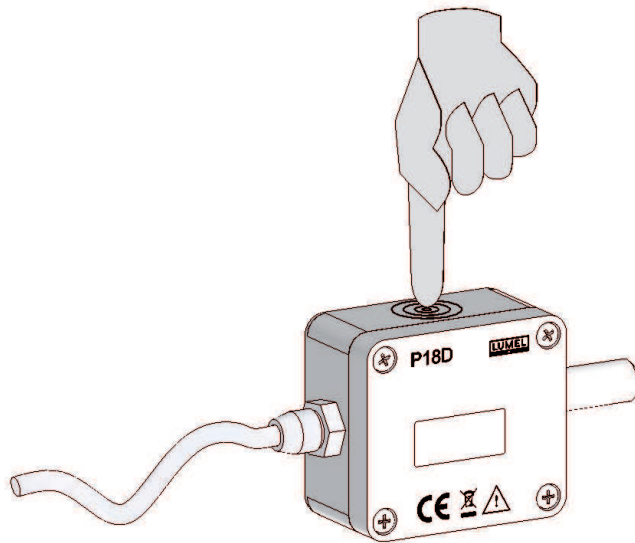

*Fig.7 The position of the capacitive button of P18D transducer.*

Functions of the capacitive button:

- switch-on of the display backlight,
- change of values presentation mode – hold down the button for about 2 seconds to switch from automatic to manual mode presentation of the measurements or vice versa
- change of measured value in the manual measurement presentation mode - a brief touch of a button changes the displayed value.

### 5.4. Functions of the P18D transducer

- measurement of ambient temperature and relative humidity,
- calculation of chosen physical quantities (dew-point temperature, absolute humidity),
- conversion of measured quantities into an output signal on the base of the individual linear characteristic,
- memory storage of maximal and minimal values for each of the measured and calculated value,
- programming of the measurement averaging time,
- RS-485 interface servicing in the MODBUS protocol, in RTU mode.

### 5.4.1. Measured and calculated values

Based on measured temperature and relative humidity the transducer P18D calculates dew-point and absolute humidity from the following relations.

DP → dew-point:

$$DP = \frac{T_n}{\frac{m}{\log \left( P_{ws} \cdot \frac{RH}{10000 \cdot A} \right)} - 1}$$

AH → absolute humidity:  $AH = 2.1668 \cdot \frac{P_{ws} \cdot RH}{100 \cdot (T + 273.2)}$

**where:**

- T** → measured temperature [°C]
- RH** → measured relative humidity [%]
- DP** → temperature of the dew-point [°C]
- P<sub>ws</sub>** → pressure of the saturated water vapour (water vapour pressure) [mbar]
- AH** → absolute humidity [g/m<sup>3</sup>]

*Coefficients for the dew-point*

*Table 2*

T [°C]	A	m	T <sub>n</sub>
< 0	6.119866	7.926104	250.4138
0...50	6.1078	7.5	237.3
50...100	5.9987	7.3313	229.1

### 5.4.3. Chosen of values for analog outputs

The P18D transducer in versions P18D-1XX and P18D-2XX has two programmable analog outputs (current or voltage). By default, the first analog output is set to present the value of the ambient temperature and the second analog output is controlled by relative humidity value. Analog outputs can respond to each of the measured or calculated value (T, RH, DP, AH). The steering value of the analog outputs define the registers respectively 4015 for the first output and 4016 for the second analog output (Table 12).

### 5.4.4. Individual Characteristic of Analog Outputs

The P18D transducer in version with analog outputs enables the conversion of measured quantities into an output signal on the strength of individual linear characteristic of analog outputs. On the base of given coordinates of two points by the user, the transducer determines (from the system of equations) coefficients  $a$  and  $b$  of the individual characteristic.

$$\begin{cases} Y1Out = a \cdot X1In + b \\ Y2Out = a \cdot X2In + b \end{cases}$$

**where:**

$X1 In$  and  $X2 In$  - measured value

$Y1 Out$  i  $Y2 Out$  - expected value on the analog output.

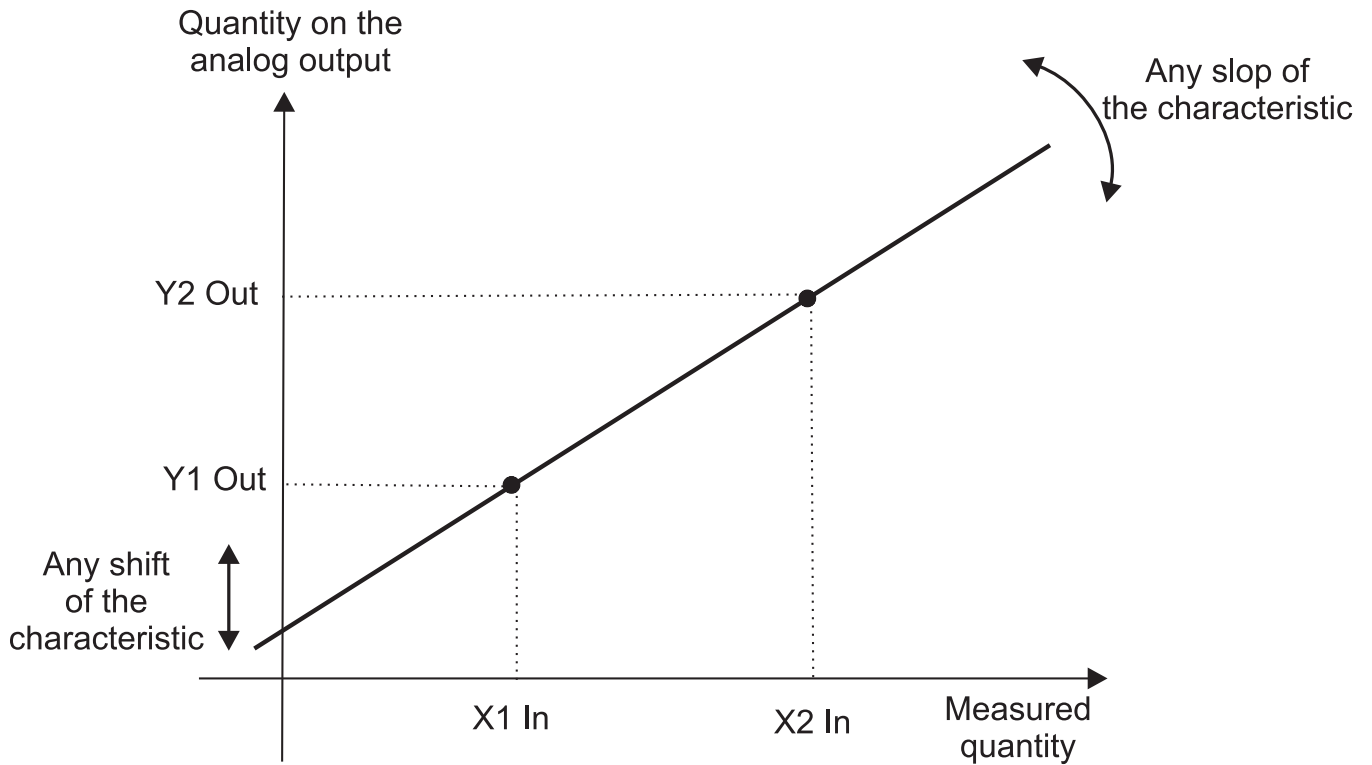

*Fig.8. Individual Characteristic of Analog outputs*

The configuration of the individual characteristic of analog outputs amounts to the introduction of suitable values X1, X2, Y1, Y2 in corresponding registers to them from the range 4007 – 4014 **tab.3**. Values introduced in these registers must be integral values corresponding to set point values multiplied by the value 100.

### **Example 1**

Configuration of the individual characteristic of the first current analog output (temperature):

The temperature conversion in the range  $-12.25^{\circ}\text{C} \div 77.75^{\circ}\text{C}$  into the analogue current signal from the range  $4.5 \div 18.5 \text{ mA}$  is expected.

*Table 3*

<b>Name</b>	<b>Register address</b>	<b>Value</b>
X1 temperature	4007	-1225
Y1 current	4008	450
X2 temperature	4009	7775
Y2 current	4010	1850

### 5.4.5. Default parameters

Table 4 shows the default parameters of P18D transducer. These settings can be restored using the RS-485 interface by writing into the 4020 register the value „1”.

Table 4

Parameter description	Parameter address	Default parameters		
		P18D-0XX	P18D-1XX	P18D-2XX
Address	4001	1		
Baud rate	4002	9600		
Mode	4003	RTU 8N2		
Averaging time	4005	30 [s]		
X1 for the first analog output	4007	0	-2000	-2000
Y1 for the first analog output	4008	0	400	0
X2 for the first analog output	4009	0	6000	6000
Y2 for the first analog output	4010	0	2000	1000
X1 for the second analog output	4011	0	0	0
Y1 for the second analog output	4012	0	400	0
X2 for the second analog output	4013	0	10000	10000
Y2 for the second analog output	4014	0	2000	1000
The first analog output steering value	4015	0	0	0
The second analog output steering value	4016	1	1	1
Special configuration	4019	8	8	8

## 6. RS-485 Interface

The P18D transducer has interface in RS-485 standard for communication with computers and with other Master devices. On the interface has been implemented MODBUS protocol.

### 6.1. Serial interface connection

Standard RS-485 port allows direct connection of up to 32 devices on a single serial link with a length of 1200 m (at a baudrate of 9600 b/s). To connect more devices it is necessary to use additional intermediate-separating devices e.g. PD51 converter/repeater of LUMEL S.A. production.

Derivation of the interface line is shown in the figure 3. To obtain a correct transmission it is necessary to connect the A and B line parallel with their counterparts in other devices. The connection of a shielded wires should be performed. The wire shield should be connected to ground terminal in the immediate vicinity of the transducer (one must connect the shield to the terminal screen protection at one point).

To connect to the PC, the RS-485 interface card or the converter, e.g. PD10 is required. How to connect your device is shown in figure 9.

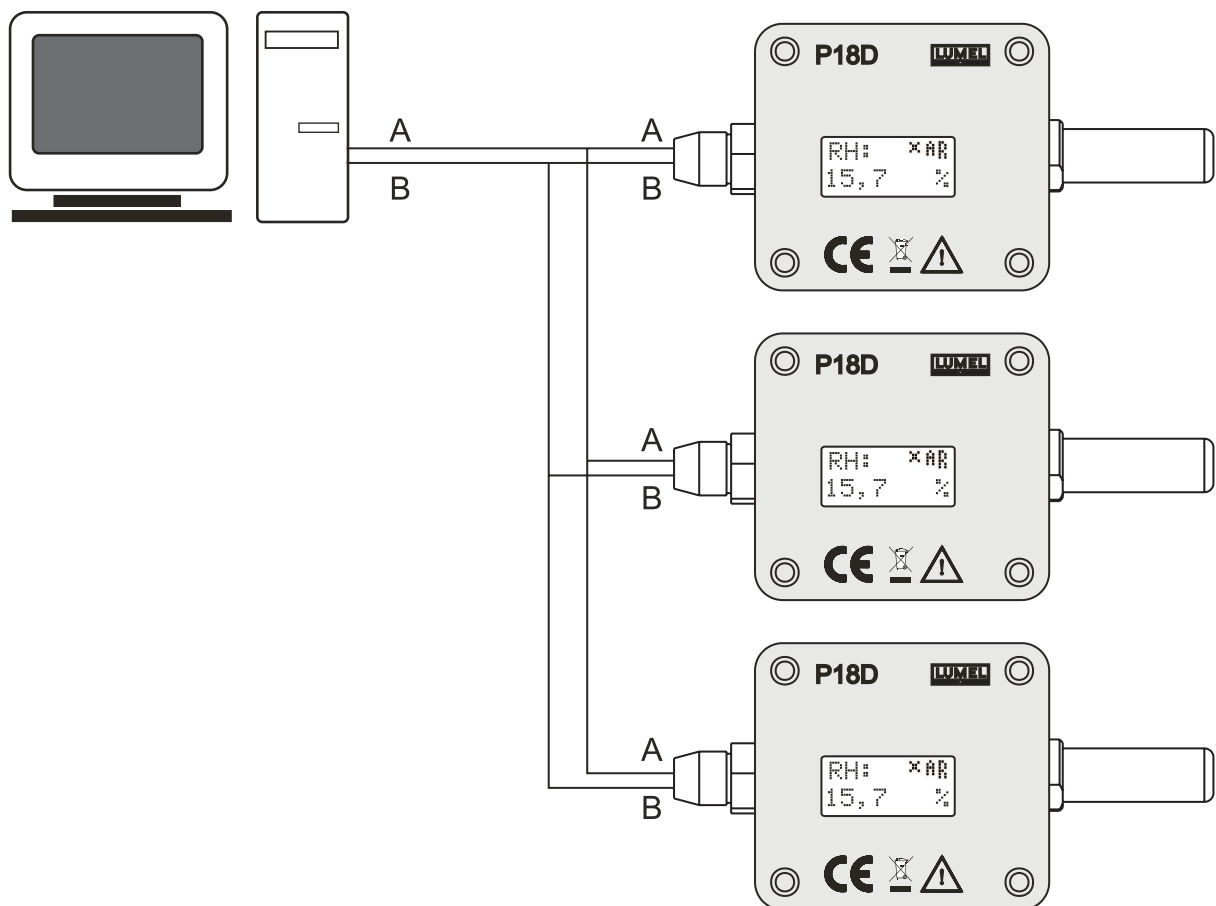

Fig.9. Connection way of RS-485 interface.



## 6.2. Description of the MODBUS Protocol Implementation

The implemented protocol is in compliance with the PI-MBUS-300 Rev G Modicon Company specification. Following functions of the MODBUS have been implemented in P18 transducers:

Set of parameters of the transducer serial link in the MODBUS protocol:

- transducer address           1... 247
- baud rate                    4800, 9600, 19200, 38400, 57600, 115200 bit/s
- work modes                 RTU: 8N2, 8E1, 8O1, 8N1
- information unit            8N2, 8E1, 8O1, 8N1
- maximal response time    500 ms

The configuration of serial link parameters consists on settlement of baud rate, device address and protocoll.

**Note:** Each transducer connected to the communication network must have:

- unique address, different from other devices connected to the network,
- the same baud rate and information unit type.

## 6.3. Description of Modbus functions

Functions of the Modbus protocol implemented in P18D transducer:

- 03 (03h) – readout of register group
- 04 (04h) – readout of input register group
- 06 (06h) – write of an single register
- 16 (10h) – write of a register group
- 17 (11h) – identification of the slave device.

## Reading-out n-registers (code 03h)

**Example 1.** Reading-out 2 registers starting with the register with the float(32 bits) 1D4Dh (7501) address, (register values 25.68, 20.25.)

Request:

Table 5

Device address	Function	Register address		Number of registers		Control sum CRC
		Hi	Lo	Hi	Lo	
01h	03h	1Dh	4Dh	00h	02h	52h 70h

Response:

Table 6

Device address	Function	Number bytes	Value from the register 1DB0 (7501)				Value from the register 1DB1 (7502)				Control sum CRC
			MSB			LSB	MSB			LSB	
01h	03h	08h	41h	CDh	70h	A4h	41h	A2h	00h	00h	83h D0h

## Recording a single register (code 06h)

**Example 2.** Recording the value 78h (120) in the register FA1h (4001)

Request:

Table 7

Device address	Function	Register address		Register value		Control sum CRC
		Hi	Lo	Hi	Lo	
01h	06h	0Fh	A1h	00h	78h	DBh 1Eh

Response:

Table 8

Device address	Function	Register address		Register value		Control sum CRC
		Hi	Lo	Hi	Lo	
01h	06h	0Fh	A1h	00h	78h	DBh 1Eh

## Recording to n-registers (code 10h)

**Example 3.** Recording the value 78h (120) and value 4h (4) in the register FA1h, FA2h (4001, 4002)

Request:

Table 9

De-vice ad-dress	Fun-ction	Register address		Number of register		Num-ber of bytes	Value for the register 4001		Value for the register 4002		Control sum CRC
		Hi	Lo	Hi	Lo		Hi	Lo	Hi	Lo	
01h	10h	0Fh	A1h	00h	78h	04h	00h	78h	00	04	F8h 31h

Response:

Table 10

Device address	Function	Register address		Number of registers		Control sum CRC
		Hi	Lo	Hi	Lo	
01h	10h	0Fh	A1h	00h	02h	13h 3Eh

## Report identifying the device (code 11h)

**Example 4.** Device identification

Table 11

Device address	Function	Control sum CRC
01h	11h	C0h 2Ch

Table 12

Device ad-dress	Fun-ction	Num-ber of bytes	Identi-fier	De-vice status	Field depending on the device software version (e.g. 0.70)	Control sum CRC
01h	11h	0Eh	CCh	FFj	50h 31h 38h 44h 76h 2Eh 30h 2Eh 30h 34h 20h 00h	B1h 54h

## 6.4 Register Map

In the P18D transducer the data is stored in 16- and 32-bit registers. The process variables and parameters of the instrument are stored in the address space of the registers in such way that they depend on the variable type. The bits in the 16-bit registers are numbered from the least significant to the most significant (b0 ... b15). The 32-bit registers (4 Bytes) contain floating-point numbers in IEEE-754 standard. Sequence of bytes: B3 B2 B1 B0 – the most significant byte is sent as the first one.

Register map of the P30U transducer is presented below.

**Note:** All the addresses given are physical addresses. In some computer programs logical addressing is applied, then the addresses should be increased by 1.

*Table 13*

<b>Address range</b>	<b>Value type</b>	<b>Description</b>
4000-4019	integer (16 bits)	The value is located in the 16-bit register.
7000-7024	float (32 bits)	The value is located i two successive 16-bit registers. Registers contain the same data as 32-bit registers from the area 7500-7512. Registers are only for readout.
7500-7512	float (32 bits)	The value is located in the 32-bit register. Registers contain measured and calculated data by the transducer. Registers are only for readout.

## 6.5. Registers for Write and Readout

Table 14

Ad- dress	Name		Range	Description	
4000	Identifier	w/r	204	Identifier of the P18D transducer	
4001	Address	w/r	1...247	Device address	
4002	Baud rate of the RS 485		0...5		Description
				0	4800 bit/s
				1	9600 bit/s
				2	19200 bit/s
				3	38400 bit/s
				4	57600 bit/s
				5	115200 bit/s
4003	Transmis- sion mode of the RS 485		0...3		Description
				0	RTU 8N1
				1	RTU 8N2
				2	RTU 8E1
				3	RTU 8O1
4004	Accep- tation of transmission parameter changes		0...1		Description
				0	no changes
				1	acceptation of changes
4005	Averaging time	w/r	6...3600	Measurement averaging time [s]	
4006	Erasing of extremes	w/r	0...1		Description
				0	no changes
				1	Erasing of min and max value

4007	X1 of inp. 1	w/r	-32768...32767	Individual characteristic of analog output	Value control inp. no 1 - pk . X1 [ x100]	
4008	Y1 of inp. 1	w/r	-32768...32767		Expected value for inp. No 1 for pt. X1	
4009	X2 of inp. 1	w/r	-32768...32767		Value control inp. no 1 - pk . X2 [ x100]	
4010	Y2 of inp. 11	w/r	-32768...32767		Expected value for inp. No 1 for pt. X2	
4011	X1 of inp. 2	w/r	-32768...32767		Value control inp. no 2 - pk . X1 [ x100]	
4012	Y1 of inp. 2	w/r	-32768...32767		Expected value for inp. No 2 for pt. X1	
4013	X2 of inp. 2	w/r	-32768...32767		Value control inp. no 2 - pk . X2 [ x100]	
4014	Y2 of inp. 2	w/r	-32768...32767		Expected value for inp. No 2 for pt. X2	
4015	Value control analog inp. No. 1	w/r	0...3	Value	Description	
				0	Temperature	
				1	Relative humidity	
				2	Dew point	
				3	Absolute humidity	
4016	Value control analog inp. No. 2	w/r	0...3	Value	Description	
				0	Temperature	
				1	Relative humidity	
				2	Dew point	
				3	Absolute humidity	

4017	Status register	w/r	-32768...32767	Transducer status. Describe current state and device configuration. Bits representing specific events. Value bit '1' means that specific event occurred.				
				Bit15	Supply reset, value write -32768 ( 8000h ) cause reset of status bit			
				Bit14	Error of calibrations parameters			
				Bit13	Incorrect transducer settings – new settings required			
				Bit12	unused			
				Bit11	unused			
				Bit10	Marker of min & max erasing , write of value 1024 ( 400h ) cause reset of status bit			
				Bit9	Temporary communication parameters (short circuit „ZW” jumper)			
				Bit8	LCD display error			
				Bit7	Error of readout value from sensor			
				Bit5,6	Value control analog inp. No. 2			
					00	01	10	11
					Temp.	RH	DP	AH
				Bit3,4	Value control analog inp. No. 2			
					00	01	10	11
Temp.	RH	DP	AH					
Bit2	Exceeding of measurement averaging time							
Bit1	Transducer with voltage analog inputs							
Bit0	Transducer with current analog inputs							

4018	Firmware version	o	1...999	Firmware version x100		
4019	Special configuration	w/r	0...31	Bit0	Value	Description
					0	Standard registers map from range 7000 and 7500
					1	Register map from range 7000 and 7500 equal with map of P14W
			Bit1...4	Number of response delay signs to the demand for RS-485 transmission.		

## 6.6. Registers only for Readout

Table 15

Value is place in two following 16-bit registers, Those register have the same value like 32-bit register from range 7500....	Value placed in 32-bit registers	Name	Write (w) / readout (r)	UNIT	Name of quantity
7000	7500	ID	r	-	ID of P18D transducer
7002	7501	T	r	°C	Measured Temperature
7004	7502	RH	r	%	Measured relative humidity
7006	7503	DP	r	°C	Calculated Dew point
7008	7504	AH	r	g/m <sup>3</sup>	Calculated absolute humidity
7010	7505	min T	r	°C	Min. temperature
7012	7506	max T	r	°C	Max. temperature
7014	7507	min RH	r	%	Min relative humidity
7016	7508	max RH	r	%	Max. relative humidity
7018	7509	min DP	r	°C	Min. Dew point



7020	7510	max DP	r	°C	Max. Dew point
7022	7511	min AH	r	g/m <sup>3</sup>	Min. absolute humidity
7024	7512	max AH	r	g/m <sup>3</sup>	Max. absolute humidity

Table 16 shows the register of measured value of the transducer P18D running in compatibility mode registers 7000 and 7500 with P14W transducer.

*Table 16*

<b>Value is place in two following 16-bit registers, Those register have the same value like 32-bit register from range 7500....</b>	<b>Value placed in 32-bit registers</b>	<b>Name</b>	<b>Write (w) / readout (r)</b>	<b>UNIT</b>	<b>Name of quantity</b>
7000	7500	ID	r	-	ID of P18D transducer
7002	7501	T	r	°C	Measured Temperature
7004	7502	DP	r	°C	Calculated Dew point
7006	7503	-	-	-	
7008	7504	RH	r	%	Measured relative humidity
7010	7505	AH	r	g/m <sup>3</sup>	Calculated absolute humidity
7012	7506	-	-	-	
7014	7507	-	-	-	
7016	7508	-	-	-	
7018	7509	min T	r	°C	Min. temperature
7020	7510	max T	r	°C	Max. temperature

7022	7511	min DP	r	°C	Min. Dew point
7024	7512	max DP	r	°C	Max. Dew point
7026	7513	-	-	-	
7028	7514	-	-	-	
7030	7515	min RH	r	%	Min relative humidity
7032	7516	max RH	r	%	Max relative humidity
7034	7517	min AH	r	g/m <sup>3</sup>	Min. absolute humidity
7036	7518	max AH	r	g/m <sup>3</sup>	Max. absolute humidity

### 6.7. Emergency restoration of default parameters

In case when standard communication parameters have been changed and the new configuration has been lost, one can set temporary on the transducer plate communication parameters by means of the jumper marked with the symbol ZW:

- transducer address            247
- baud rate                        9600kb/s
- mode                                RTU 8N2

*After removing the jumper, the transducer returns to previous settings or to settings changed during the operation with the jumper.*

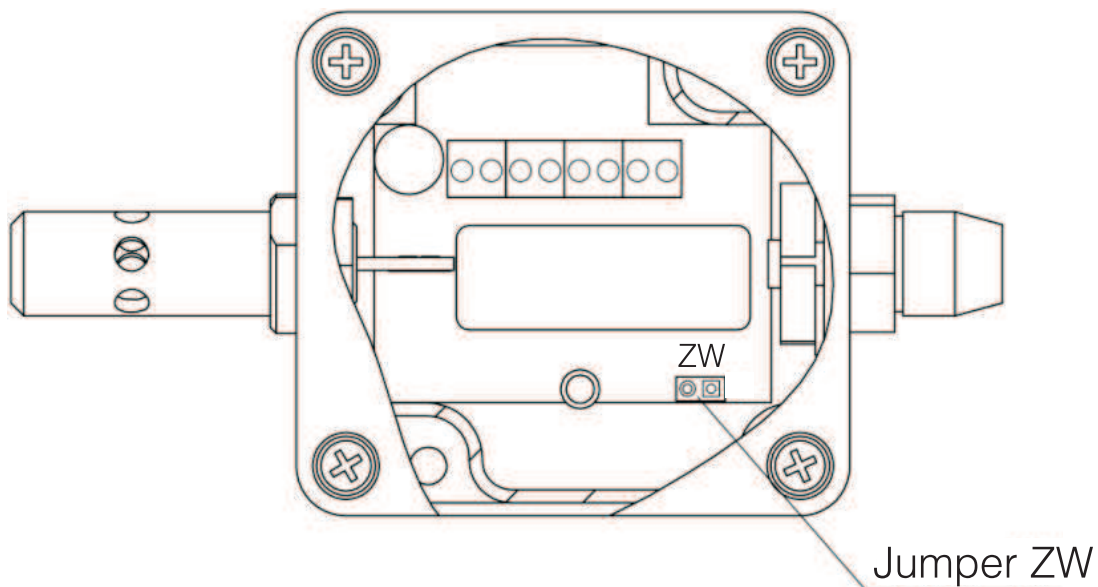

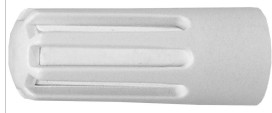

**Fig. 10. Placement of the Jumper Setting Temporary Communication Parameters.**

## 7. ACCESSORIES

As a standard, the P18 transducer is equipped with a metallic shield of the sensor, destined only for indoors applications, for outdoors or indoors applications exposed to the possibility of water vapour condensation, it is recommended to use additional shields of the sensor (interchangeable), depending of the transducer working conditions.

Table 9

Sensor protection shields

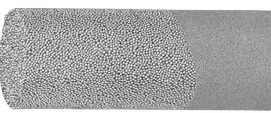
Item	Order code	Design	Name	Construction	Features	Typical application
1	0874-490-016		Membrane filter	Casing made of PVC Membrane of teflon. laminated by a film Pore size: 1 µm	Mean filtration effect. Maximal temp.: up to 80°C Response time: t10/90:15 s	Building automation. In rooms with low pollution
2	0874-490-015		Filter made of teflon	Sintered teflon Pore size: 50 µm	High chemical resistance Maximal temp.: up to 180 °C Response time: t10/90:14 s	Drying process in chemical applications
3	0874-490-014		Filter made of sintered bronze	Sintered bronze Pore size: 60 µm	High mechanical resistance. To co-operate with high pollution. Applied at small air humidity Response time: t10/90:10 s	Agricultural applications

## 8. TECHNICAL DATA

### Basic parameters:

- range of relative humidity measurement (RH) 0...100%, without condensation <sup>1)</sup>
- basic error of humidity conversion  $\pm 2\%$  of the range for RH=10...90%  
 $\pm 3\%$  for the remaining range
- hysteresis of the humidity measurement  $\pm 1\%$  RH
- basic range of temperature measurement - 20...60°C <sup>2)</sup>
- basic error of temperature conversion calculated quantities  $\pm 0.5\%$  of the range  
absolute humidity (a) [g/m<sup>3</sup>]  
dew-point temperature (Td) [°C]
- **additional errors:**
  - temperature influence  $\pm 25\%$  of the basic error/10°C

\* for versions with analog outputs P18D-1 or P18D-2 error processing core temperature can increase by 0,2 °C

### RS-485 digital output:

- transmission protocol MODBUS
- baud rate 4800, 9600, 19200, 38400, 57600, 115200 bit/s
- mode RTU: 8N2, 8E1, 8O1, 8N1
- maximal response time 500 ms

### Analog outputs:

- current 4...20 mA
- voltage 0...10 V
- maximal load resistance of the current output 100 Ω
- maximal load resistance of the voltage output 1 kΩ

### Rated operating conditions:

- supply	9...24 V a.c./d.c.
- consumption	< 0.5 VA
- ambient temperature	- 20...23...85°C
- relative air humidity	< 95% <sup>3)</sup>
- rate of air flow	≥ 0.5 m/sec <sup>4)</sup>
- pre-heating time	15 minutes
- protection degree ensured by the housing	IP 65
- fixing	on a wall
- weight	0,13 kg
- dimensions	(35 × 58 × 118) mm
- working position:	
• in applications non-exposed to a direct contact with water	any
• in applications exposed to a direct contact with water	with the sensor chamber directed towards the ground.

### Electromagnetic compatibility:

- noise immunity	acc. to EN 61000 -6-2
- noise emission	acc. to EN 61000 -6-4

### Security requirements acc. to EN 61010 -1:

- installation category	III
- pollution grade	2
- phase-to-earth working voltage	50 V
- altitude above sea level	< 2000 m

---

1) In case of condensation of water vapour on the sensor surface, the error measurement does not exceed the basic error till the moment of drying up the sensor structure.

2) The absolute temperature measurement range is -30...85°C, but beyond the basic range, the measurement class is not guaranteed.

3) Admissible condensation of water vapour when using additional sensor shields, (see table 9).

4) For the air flow < 0.5 m/s, the temperature and humidity measurement error can grow of 100%.

## 9. ORDERING CODES

### Ordering Codes of P18D Transducer Versions

Table 18

	<b>P18D -</b>	X	XX	X	X
<b>Analog outputs:</b>					
lack		0			
current 4...20 mA		1			
voltage 0...10 V		2			
<b>Version:</b>					
standard			00		
non standard setting			NS		
custom-made*			XX		
<b>Language:</b>					
Polish				P	
English				E	
other*				X	
<b>Acceptance tests:</b>					
without extra quality requirements					0
with an extra quality inspection certificate					1
according to customer's request *					X

\* After agreeing with the manufacturer.

### Example of Order:

The code: **P18D - 1 00 E 8 0** means:

- P18D** - humidity and temperature transducer
- 1** - current output: 4...20 mA
- 00** - standard version
- E** - english language
- 0** - without additional quality inspection certificate.

## **8. MAINTENANCE AND GUARANTEE**

The P18D transducer does not require any periodical maintenance.  
In case of some incorrect operations:

### **1. In the period of 12 months from the date of purchase:**

One should take the transducer down from the installation and return it to the Manufacturer Quality Control Dept.

If the unit has been used in compliance with the instructions, the Manufacturer guarantees to repair it free of charge.

### **2. After the guarantee period:**

One should turn over the transducer to repair it in a certified service workshop.

The disassembling of the housing causes the cancellation of the granted guarantee.

**Our policy is one of continuous improvement and we reserve the right to make changes in design and specifications of any products as engineering advances or necessity requires and revise the above specifications without notice.**



**“LUMEL” S.A.**

ul. Słubicka 1

65-127 Zielona Góra - Poland

tel.: (48-68) 45 75 100 (exchange)

fax: (48-68) 45 75 508

e-mail: [lumel@lumel.com.pl](mailto:lumel@lumel.com.pl)

<http://www.lumel.com.pl>

**Export Department:**

Tel.: (48-68) 45 75 302 or 304

Fax: (48-68) 325 40 91

e-mail: [export@lumel.com.pl](mailto:export@lumel.com.pl)