

Energom-2M1D

Single Phase Energy Meter



Version: 1.10

Revision: 2024.09

Read me

When you use EnergoM-2M1D single phase energy meter, be sure to read this user manual carefully, and be able to fully understand the implications, the correct guidance of operations in accordance with user manual, which will help you make better use of EnergoM-2M1D single phase energy meter, and help to solve the various problems at the scene.

1. Before the meter turning on the power supply, be sure that the power supply within the provisions of the instrument;
2. When installation, the current input terminal must non-open, voltage input terminals must Non-short circuit;
3. Communication terminal (RS232/RS485) is strictly prohibited to impose on high pressure;
4. Be sure the instrument wiring consistent with the internal system settings;
5. When communicating with the PC, instrument communication parameters must be consistent with the PC.



- **Please read this user manual carefully**
- **Please save this document**

Directory

1. - SUMMARIZE.....	3
2. - TECHNICAL PARAMETERS	4
3. - INSTALLATION AND START-UP.....	5
3.1. - INSTALLATION	5
3.2. - TYPICAL WIRING	8
4. - SCREEN DISPLAY	9
4.1. - SCREEN DESCRIPTION:	9
5. - OPERATION MENU DESCRIPTION	10
5.1. - BUTTON DESCRIPTION.....	10
5.2. - MAIN MENU	11
5.3. - DESCRIPTION OF MENU CHARACTERS:.....	12
6. - COMMUNICATION INTERFACE	14
6.1. - CONNECTION FOR RS485 BUS.....	14
6.2. - MODBUS © PROTOCOL	15
6.3. - REGISTER MAP	15
6.3.1. - BASIC POWER DATA - PRIMARY SIDE	15
6.3.2. - EXAMPLE	17
7. - SAFETY CONSIDERATIONS	18
8. - MAINTENANCE	18
9. - TECHNICAL SERVICE	19

1. - SUMMARIZE

Energom-2M1D single phase energy meter is suit for single-phase measurement, application such as residential, public facilities, and industrial use.

Energom-2M1D can measure and display various important power parameters, optional communication ports support remote reading and monitoring. Bi-direction metering makes Energom-2M1D is an excellent choice for solar energy industry.

FEATURES

- Provide energy import and export measurement (IMP & EXP);
- Detect active/reactive energy, power, frequency, max demand, voltage, current, etc;
- High light white backlit LCD screen;
- Energy pulse output;
- RS485 Modbus communication (optional);
- Standard 35mm din rail mounting;
- Maximum 100A current access;
- Accuracy: Class 1.0s;

APPLICATIONS

- All power parameter measurement;
- Energy measurement and electrical fire monitor and control;
- Transformers, generators, capacitors and electric motors distributed detection;
- Medium and low pressure systems;
- SCADA, EMS, DCS integrators.

2. - TECHNICAL PARAMETERS

Measurement & Display

Voltage	Rated 230V RMS value, Accuracy 0.5%,
Current	Rated 10A, Max 100A, Start amp 0.04A, RMS value. Accuracy 0.5%; Overload 30times In in 0.01sec
Frequency	50/60Hz, Accuracy ± 0.01 Hz
Display	LCD with white backlit
Maximum display value	9999999MkWh
AUX Power	Self-powered

Output

Digital port	RS-485 MODBUS-RTU
Pulse port	1600imp/kWh

Other

Working environment	-25~55°C Altitude ≤ 2500 m, 0~95%RH, non-condensing, non-corrosive gas
Storage environment	-40°C ~70°C
Voltage tolerance	2KV 1min
Shock voltage	6KV-1.2uS waveform
Insulation	Input, output, power supply to Shell $> 5M\Omega$

3. - INSTALLATION AND START-UP



The manual you hold in your hand contains information and warnings that the user should respect in order to guarantee a proper operation of all the instrument functions and keep it in safety conditions. The instrument must not be powered on and used until its definitive assembly is on the cabinet's door.

If the instrument is not used as manufacturer's specifications, the protection of the instrument will be damaged.

When any protection failure is suspected to exist (for example, it presents external visible damages), the instrument must be immediately powered off. In this case contact a qualified service representative.

3.1.- Installation

Mounting

Instrument is to be mounted on 35mm Din-rail. Keep all connections into the cabinet. Please note that with the instrument powered on, the terminals could be dangerous to touch and cover opening actions or elements removal may allow accessing dangerous parts. Therefore, the instrument must not be used until this is completely installed.

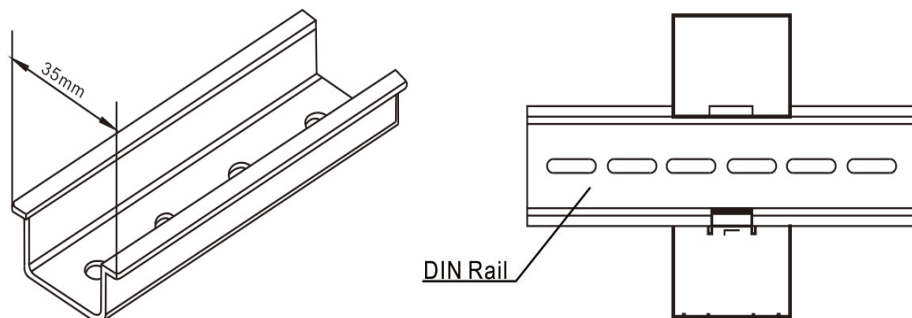
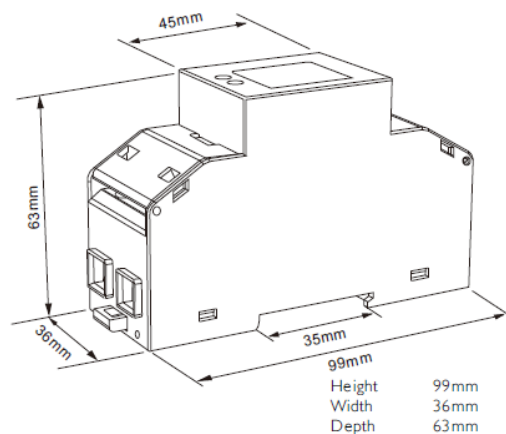

Notes:

Input signal: EnergoM-2M1D using a separate acquisition calculate for each measurement channel, to ensure consistent in use, for different load forms, it's a variety of connection mode. Access wire shall be met 3 square mm.

A. Voltage input

Input voltage should not exceed the rated input voltage products 450V.
Otherwise, you should use external VT. Suggest 1A fuse be installed in the voltage input side.

B. Current Input

Standard input current is 5A or 1A, if greater than 5A/1A should use external CT.
When the CT is connected with other meters, make sure wiring methods be used in series.

Warning: Forbid to install a CT on the live feeder wire with open secondary leads. This can be extremely dangerous!

Before remove the current input connection, must be sure to disconnect the primary circuit or shorted secondary circuit of CT.

C. Sequence of wire

Warning: Please make sure that the input voltage and current corresponding to the same phase, sequence, and the same direction; Otherwise, the Values and symbols will be wrong! (Power and Energy)

Always observe the physical orientation of CT (P1 - P2) when installing on the feeder wire.
Always pay attention to wiring polarity and phasing when terminating the CT leads to the 19D-23C. S1 connect to Ix*, S2 connect to Ix.

The input network configuration of instrument depends on the CT number of the system:
in the condition of 2 CT, select the three-phase, three-lines two components;
in the condition of 3 CT, select the three-phase, four-lines three component mode.

Instrument connection mode, set of the instrument (programming input network NET) should be the same load wiring as measured wiring. Otherwise, the measurement instrument will lead to incorrect voltage or power.

D. Auxiliary power

Energom-2M1D with universal (AC / DC) power input, if not for a special statement, we provide the 90-240AC/DC power interface for standard products, please ensure that the auxiliary power can match with meter to prevent unexpected damage.

- A. Suggest install 1A fuse in the fire line side.
- B. For the areas with poor power quality, suggest install lightning surge suppressor and rapid burst suppressor to prevent lightning strikes.

3.2. - Typical Wiring

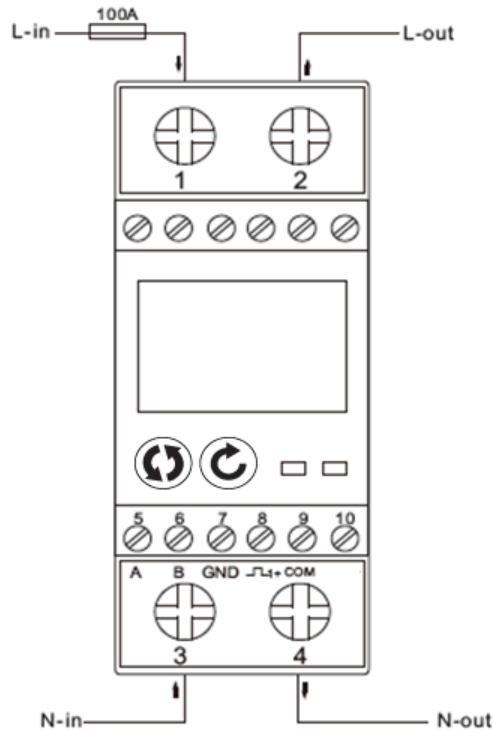

Note:

This connection drawing is for reference only; the actual connecting terminal please refer to the label on the rear part.

WARNINGS!

- Must choose suitable cable size to connection, please refer the meter measurement range and actual load condition.
- The communication wire must use shielded twisted pair.
- Communication line RS485+, RS485- cannot be reversed.
- If need long distance communication to host, must parallel connect 100~120ohms resistor in both terminal of host to slave.
- In 9600 baud rate, the cable length should less than 1200 meters.

4. - SCREEN DISPLAY

4.1.- Screen description:



- 1.- 7 Digital show energy value
- 2.- Symbol for SUM energy record value
- 3.- Symbol for multi-tariff function
- 4.- Imp for energy consumption, Export for energy generate
- 5.- Symbol for Maximum demand
- 6.- Symbol for average value
- 7.- PF=power factor; Hz=Frequency
- 8.- Pulse output channel 1 and channel 2
- 9.- Symbol for communication active
- 10.-Symbol for timer
- 11.- Symbol for screen locked

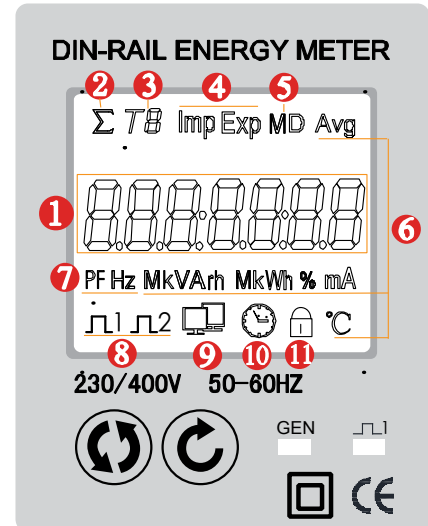

Click for “left”, can move cursor to left or change to forward screen

Press and hold for Enter operation menu



Click for “right”, can move cursor to right or change to next screen, Press and hold for confirm setting

5. - OPERATION MENU DESCRIPTION

5.1. - Button description



Short press is the left key to switch the viewing interface;

Long press is the menu key to enter and modify parameters.

Short press is the right key to switch the viewing interface;

Long press is the confirmation key to save the modified data.

5.2. - Main menu

In regular measurement screen, press and hold **Ⓢ** button can access operation screen. Panel main area will show "Pass" for ask password, then press and hold **Ⓢ** button can entry password (default are 0001).

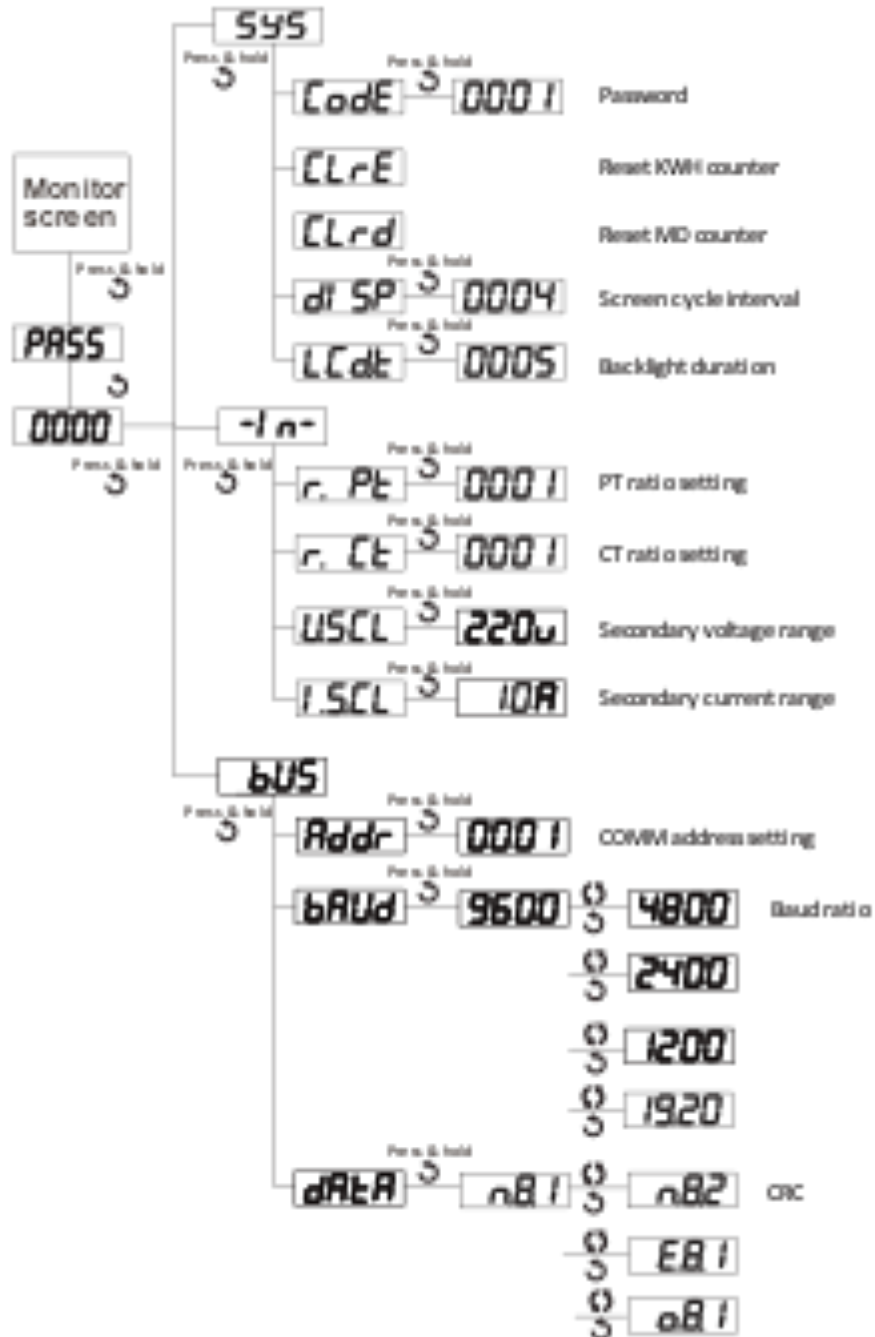

5.3. - Description of menu characters:

PASS	(Password) User password
Erro	(Error) Wrong input information
-I n-	(Input) User Display data settings menu
bUS	(Bus) Communication settings menu
SYS	(System) System settings menu (for factory debugging, not open yet)
Code	(Code) Enter password
dAtA	(Data) Communication parameter setting
Addr	(Address) Local communication address setting
bAUd	(Baud) Communication baud rate
oB.1	(o.8.1) Indicates 8 data bits, 1 stop bit, odd parity
E.B.1	(e.8.1) Indicates 8 data bits, 1 stop bit, even parity
nB.1	(n.8.1) Indicates 8 data bits, 1 stop bit, no parity bit
USCL	(U.scl) Select rated input voltage
ISCL	(I.scl) Select rated input current
r. Ct	(R.ct) Set the current multiplier
r. Pt	(R.pt) Set voltage ratio
SYS	(System) System settings menu (for factory debugging, not open yet)

TYPE

(Type) What parameters to set

PARA

(Para) Corresponding parameter selection

VALU

(Value) Set the corresponding alarm value

Code

(Code) Modify password value

YEAR

(Year) Set year

MON

(Month) Set month

DAY

(Day) Set day

DATE

(Date) Set date

Hour

(Hour) Set hour

MIN

(Min.) Set minute

SEC

(Second) Set second

E.SEG

(Seg,.) Set segment

ENOD

Rate

FLAT

Flat

LOW

Valley

LINE

Sharp

PEAK

Peak

EDAY

Meter reading time setting

6. - COMMUNICATION INTERFACE

6.1.- Connection for RS485 BUS

The composition of the RS-485 cabling must be carried out with a meshed screen cable (minimum 3 wire), diameter of not less than 0.5mm², with a maximum distance of 1,200 m between the EnergoM-2M1D... and the master unit. This Bus may connect a maximum of 32pcs.

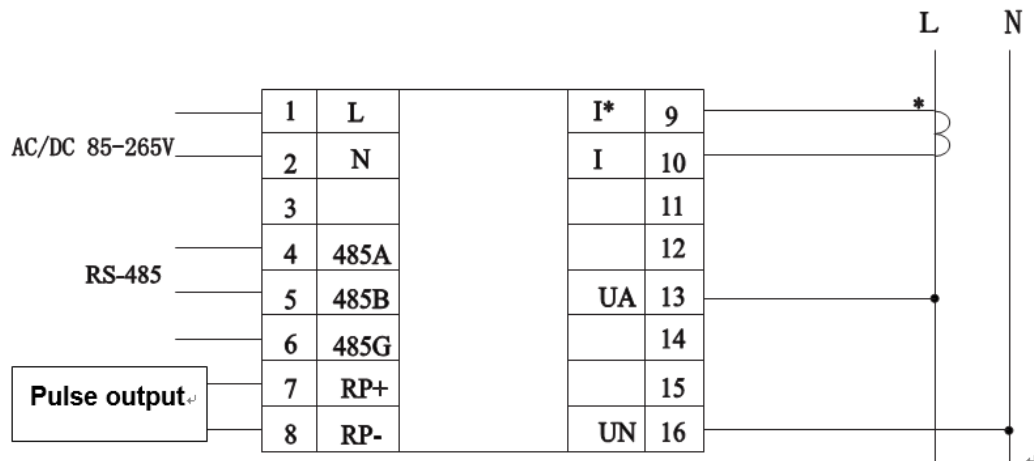

Notes:

- For communication with the master unit, user can choose RS-485 to RS-232 converter or RS485 to USB adapter to use.
- For expand the number of devices in the communication network, a signal repeater can be used.
- RS485 PIN number is 58,59,60.
- Due to product modifications or special requirements, the interface pin place may be change. For details, please refer to product label on the rear side.

6.2.- MODBUS © Protocol

Modbus RTU Frame Format:

Address code	1 BYTE	<i>Slave device address 1-247</i>
Function code	1 BYTE	<i>Indicates the function codes like read coils / inputs</i>
Data code	4 BYTE	<i>Starting address, high byte Starting address, low byte Number of registers, high byte Number of registers, low byte</i>
Error Check code	2 BYTE	<i>Cyclical Redundancy Check (CRC)</i>

MODBUS FUNCTIONS:

Code	Meaning	Description
FUNCTION 01	Read Coil Status	<i>Only valid when equipped DO port</i>
FUNCTION 02	Read Input Status	<i>Only valid when equipped DI port</i>
FUNCTION 03	Reading of n Words	<i>This function permits to read all the electrical parameters</i>
FUNCTION 05	Force Single coil	<i>When DO in remote control mode can work</i>
FUNCTION 06	Preset Single register	<i>Disable in default</i> <i>If need valid this code, please contact Energometrika Sales Team before your order!</i>

Note: Float data follow **IEEE754**, float low bit first, high bit next. **(CD AB)**

6.3.- Register Map

6.3.1.- Basic power data - Primary side

Address	Data	Byte mode	Notes
----------------	-------------	------------------	--------------

0x00	U	float	2	Phase to line voltage, Unit: V
0x0c	I	float	2	Current, Unit: A
0x12	P	float	2	Active power, Unit: kW
0x1a	Q	float	2	Reactive power, Unit: kVar
0x22	S	float	2	Apparent power, Unit: kVA
0x2a	PF	float	2	Power factor, 0~1.000
0x32	FR	float	2	Frequency, Unit:0.01Hz
0x34	Ep+	float	2	Positive active energy, Unit: kWh
0x36	Ep-	float	2	Negative active energy, Unit: kWh
0x38	Eq+	float	2	Inductive reactive power, Unit: kVarh
0x3a	Eq-	float	2	Capacitive reactive power

6.3.2.- Example

Host inquiry slave device

Addr.	Func.	Data Address high	Data Address low	Data Number high	Data number low	CRC16 low	CRC16 high
0CH	03H	00H	00H	00H	06H	C4H	D5H

PC user ask upload UA, UB, UC, IA, IB, IC

Slave device response

Addr.	Func.	Byte count	Data1 high	Data1 low	Data2 high	Data2 low	Data3 high	Data3 low
0CH	03H	0CH	03H	E8H	03H	E9H	03H	E8H
Data4 high	Data4 low	Data5 high	Data5 low	Data6 high	Data6 low	CRC16 low	CRC16 high	
13H	84H	13H	88H	13H	8AH	A6H	D6H	

Show the data:

UA=3E8H (100.0)
 UB=3E9H (100.1)
 UC=3E7H (99.9)
 IA=1384H (4.996)
 IB=1388H (5.000)
 IC=138AH (5.002)

Notes:

1. Energometrika disable the 06 function in default setting, if Activated the write command, please check the host device program to avoid the meaningless write operation, that may reduce the register working life
2. When the write is unsuccessful, no return data from the slave device. In this addition, please re-send write inquiry again.

7. - SAFETY CONSIDERATIONS



All installation specification described at the previous chapters named:
INSTALLATION AND STARTUP, INSTALLATION MODES and SPECIFICATIONS.

Please note that with the instrument powered on, the terminals could be dangerous to touching and cover opening actions or elements removal may allow accessing dangerous parts. This instrument is factory-shipped at proper operation condition.

- ◆ The device must have a professional installation and maintenance
- ◆ Any operation of the device, you must cut off the input signal and power;

8. - MAINTENANCE

The EnergoM-2M1D single phase energy meter does not require any special maintenance. No adjustment, maintenance or repairing action should be done when the instrument is open and powered on, should those actions are essential, high-qualified operators must perform them.

Before any adjustment, replacement, maintenance or repairing operation is carried out, the instrument must be disconnected from any power supply source.

When any protection failure is suspected to exist, the instrument must be immediately put out of service. The instrument's design allows a quick replacement in case of any failure.

9. - TECHNICAL SERVICE

FAQ's

- 1.- Once cabled and connected is seen to give a correct voltage and current reading, but shows negative values for active power (generation).

This is an error with the cabling for the current transformer secondary; the direction of the transformer current has to be respected as shown in the connection diagram. The current transformers have a two face primary; the current must pass from P1 to P2 giving the result in secondary (S1 and S2) of 5 amps.

The error stems from:

- a). The current transformers have been incorrectly installed. As a result, it gives the direction of the current as passing from P2 to P1; to resolve this problem, the current transformer does not have to be dismantled and installed again, but the transformer secondary (S1 and S2) just has to be inverted.
 - b). The connection of the current secondary in the current transformers have been incorrectly connected; to resolve this problem just connect the S1 transformer secondary to the S1 on the meter and the S2 on the current transformer to the S2 on the meter.
- 2.- Once cabled and connected, is seen to give an incoherent Power factor and $\text{Cos}\Phi$ reading (-0.01 or similar).

This is again a current transformer and voltage phase connection error phase A, must correspond to the current transformer installed in phase A; phase B, must correspond to the current transformer installed in phase B; and phase C, must correspond to the current transformer installed in phase C.

This connection terminal is clearly shown on the area side of the device.

- 3.- The measuring voltage and is displaying the secondary voltage (for example 110 volts). Ensure that the voltage Transformer ratio has been correctly set.
- 4.- Device does not correctly display the current reading. It shows values varying between 0 to 5 amps of current. Ensure that the Current Transformer ratio has been correctly set.

Calculation formula of electrical parameter

Formula	Parameter
$U = \sqrt{\frac{1}{N} \sum_{n=0}^N u_n^2} \quad n = 0, 1, 2, \dots, N$	Voltage RMS value
$I = \sqrt{\frac{1}{N} \sum_{n=0}^N i_n^2} \quad n = 0, 1, 2, \dots, N$	Current RMS value
$P = \frac{1}{N} \sum_{n=1}^N (i_{an} u_{an} + i_{bn} u_{bn} + i_{cn} u_{cn})$	Total active power cycle average
$P_s = UI$	Single-phase apparent power cycle average
$\cos\theta = \frac{P_p}{P_s}$	Power factor
$P_q = \sqrt{P_s^2 - P_p^2}$	Reactive power (Pq is positive and the direction cannot be determined; P algorithm can be used to shift the voltage component by 90°)
$W = \int P^* dt$	Electric energy

Note: In above formula, N for sampling points in one AC wave.