

## TTC-KR series Rogowski coil three phase integrator

TTC-KR series Rogowski coil three phase integrator, can be true to restore the input current and at the same time have a certain filter amplification, so that the waveform is more smooth and practical, wide measuring range, high precision, stable and reliable response and wide frequency band etc., Widely used in metallurgy, electroplating, frequency control and other fields.



### Electrical data (Ta=25°C±5°C)

Current range(AC)		100-100K	A(ac)
Measure range		5% - 120%	%
Power frequency		45-65	Hz
frequency band		10 - 10KHz	Hz
Rated output		0.1-5Vac (333mVac)	Vac
Supply voltage		12 - 30V	V
Power Consumption		<30	mA
Offset voltage		≤3	mV
Offset drift	@ -25~+70°C	≤±1	mV/°C
Accuracy		≤1	%
Linearity		≤1	%FS
Response time		≤20	ms
Galvanic isolation	AC,1min	10	KV
Isolation resistance	@ DC 500V	1000	MΩ
Operating temperature		-25 to +50	°C
Storage temperature		-40 to +70	°C

## Mechanical dimension(for reference only)

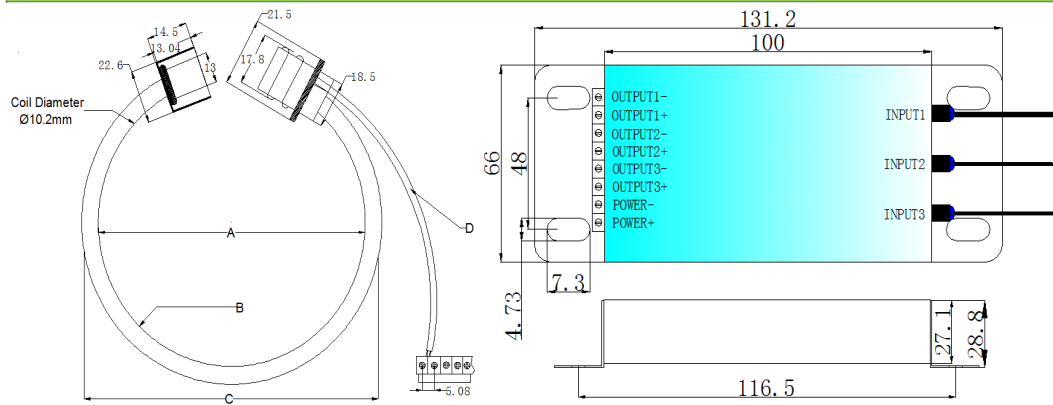

A(mm)	B(mm)	C(mm)	D(m)
≤600	10.5	A + 2*B	≤50
Custom made	10.5	Custom made	Custom made

## Directions for use

1. The wiring should be connected according to the label instructions, especially three-phase integrator must be AC voltage input interface device can be connected. Otherwise the value will be displayed error. (Note: The false wiring may result in the damage of the integrator )

2. Custom design in the different rated input current and the output voltage are available.

## Characteristics chart

Input-output characteristic curve

