

# **Energom-PR240 series**

## **Motor Protect Relay**

### **User Manual**

**Version 3.7**

**Revision 2022-8**

## Read me

**When you use EnergoM-PR240 series intelligent motor protection relay, be sure to read this user manual carefully, and be able to fully understand the implications, the correct guidance of operations in accordance with user manual, which will help you make better use of BJ- PR200 series motor protector, and help to solve the various problems at the scene.**

1. Before the meter turning on the power supply, be sure that the power supply within the provisions of the instrument;
2. When installation, the current input terminal must non-open, voltage input terminals must Non-short circuit;
3. Communication terminal (RS232/RS485 or Ethernet) is strictly prohibited to impose on high pressure;
4. Be sure the instrument wiring consistent with the internal system settings;
5. When communicating with the PC, instrument communication parameters must be consistent with the PC.



- **Please read this user manual carefully**
- **Please save this document**

## Directory

<b>1. - SUMMARIZE.....</b>	<b>- 4 -</b>
<b>2. - FEATURES .....</b>	<b>- 4 -</b>
<b>3. - SPECIFICATIONS .....</b>	<b>- 5 -</b>
<b>4.- INSTALLATION AND START-UP .....</b>	<b>- 9 -</b>
4.1.- INSTALLATION .....	- 9 -
4.1.- TERMINAL DEFINITION .....	- 11 -
<b>TERMINAL DEFECTION .....</b>	<b>- 11 -</b>
<b>5. OPERATION MODE.....</b>	<b>- 12 -</b>
5.1- LCD DISPLAY SCREEN .....	- 12 -
5.2- PANEL LED INDICATOR .....	- 12 -
5.3- MOTOR CONTROL BUTTONS .....	- 13 -
5.3- CONFIGURATION BUTTONS .....	- 14 -
5.4- MEASUREMENT INTERFACE .....	- 15 -
5.5- CONFIGURATION INTERFACE.....	- 16 -
<b>6. - RS485 COMMUNICATION PORTOCOL.....</b>	<b>- 23 -</b>
6.1.- MODBUS © PROTOCOL .....	- 23 -
6.1.1- <i>Modbus RTU Frame Format:</i> .....	- 23 -
6.1.2.- <i>Modbus function code</i> .....	- 24 -
6.2.- MOTOR STATUS PARAMETER (READ ONLY, CODE 04) .....	- 26 -
6.3.- MOTOR BASIC CONFIGURATION (READ AND WRITE) .....	- 29 -
6.4.- MOTOR PROTECTION FUNCTIONS CONFIGURATION (READ AND WRITE) .....	- 30 -
6.5.- MOTOR START MODE CONFIGURATION (READ AND WRITE).....	- 32 -
6.5.- SEQUENCE OF EVENT RECORD (READ ONLY, CODE 04).....	- 33 -
6.5.- MOTOR ADVANCED CONTROL (READ AND WRITE) .....	- 34 -
<b>7.- PORTECTION FUNCTION INTRODUCTION .....</b>	<b>- 35 -</b>
7.1- START OVERTIME PROTECTION .....	- 35 -
7.2- OVERLOAD PROTECTION.....	- 36 -
7.3- JAM IN RUNNING PROTECTION (STALL) .....	- 40 -
7.4- JAM IN STARTING PROTECTION (ROTOR LOCKED) .....	- 40 -
7.5- PHASE FAILURE PROTECTION.....	- 40 -
7.6- CURRENT IMBALANCE PROTECTION .....	- 41 -
7.7- GROUND FAULT PROTECTION .....	- 41 -
7.8- UNDER POWER PROTECTION .....	- 42 -
7.9- OVER TEMPERATURE PROTECTION.....	- 42 -
7.10- SHORT CIRCUIT PROTECTION .....	- 42 -
7.11- OVER VOLTAGE PROTECTION .....	- 43 -
7.12- UNDER VOLTAGE PROTECTION .....	- 43 -

7.13- ABNORMAL FREQUENCY PROTECTION .....	- 44 -
7.14- ABNORMAL POWER FACTOR PROTECTION.....	- 45 -
7.15.- TE PROTECTION .....	- 45 -
<b>8- MOTOR START MODE INTRODUCTION.....</b>	<b>- 47 -</b>
8.1.- ONLY PROTECTION MODE .....	- 47 -
8.2.- FULL VOLTAGE START MODE.....	- 49 -
8.3.- FORWARD AND REVERSE START MODE.....	- 50 -
8.4.- TWO-WINDING START MODE .....	- 51 -
8.5.- WYE-DELTA TRANSITION MODE.....	- 52 -
8.6.- AUTOTRANSFORMER CLOSED TRANSITION MODE .....	- 53 -
8.7- CIRCUIT BREAKER DIRECTLY START MODE .....	- 54 -
<b>9. - SAFETY CONSIDERATIONS.....</b>	<b>- 55 -</b>
<b>10. - MAINTENANCE.....</b>	<b>- 55 -</b>

## 1. - SUMMARIZE

Energom-PR240 motor protection relay is an all-in-one solution designed to continuously monitor 3-phase power lines for abnormal conditions. It can use with motors less than 690V/820A. It can realize a variety of control operation, as well as measurement, self-diagnosis, maintenance management, field bus communication and other functions.

The series of products through the real-time monitoring of the scene signal, provide various protection trip to avoid motor failure. Option RS485 communication port can upload the monitor data and alarm status to remote control system.

<b>Protection function (Details please refer to chapter 7)</b>	<b>Real-time monitor parameter</b>
Start Overtime (Max. Start time), Over Load,	Three-phase current, Three-phase line voltage,
Phase Failure (Phase loss), Jam in starting(Stall),	Frequency, Active power,
Current imbalance, Under power,	Reactive power, Apparent power,
Jam in running, Ground fault,	Power factor, Electrical energy,
Over temperature, Short circuit,	Ground residential current
Over voltage, Under voltage,	
Abnormal frequency, Abnormal power factor,	
tE protection (Increased safety motor overload) Automatic restart,	

## 2. - FEATURES

- Various electrical parameter real-time detect, Dot matrix LCD display.
- Built-in 4-channels relay, provide various start methods: Direct start, positive & negative start, star - delta start, autotransformer start, 2-speed motor start, circuit breaker direct start and protection trip logic.
- User free to set each protection function act off, alarm or trip.
- Build in Sequence of Event function, can logger last 100 trip records.
- With programmable analog output function, user option RS-485 communication interface.

### 3. - SPECIFICATIONS

#### Working environment:

Motor rated voltage:	AC380V / AC660V
Motor rated current:	0.5-820A
Working temperature:	-10C ~ +55C
Storage temperature:	-25C ~ +70C
Relative humidity:	< 93% RH
Elevation:	not more than 3000 m
Atmospheric conditions:	installation site does not allow the explosive medium, containing gas to corrode metal and damage the insulation and conductive medium.

#### Measuring accuracy:

Current:	$\pm 0.5\%$ @ 10% to 200% of $I_e$
Voltage:	$\pm 0.5\%$ @ 10%~150% $U_e$
Frequency:	$\pm 0.1\%$ @ 45 ~ 65Hz
Power factor:	$\pm 1.0\%$ @ 0 ~ 1.000
Active Power	$\pm 1.0\%$ @ 0 ~ 500kW
Leakage current:	$\pm 1\%$ @10% to 100% of $I_r$
Analog Output:	$\pm 1\%$ @4 ~ 20mA

#### Electrical parameters:

Auxiliary Power:	AC90-240Vac/dc
Power consumption:	<10 VA
Insulation resistance:	> 100M $\Omega$
Relay:	Alarm relay @ 5A / 250VAC, 5A / 30VDC (NO node)

**Electrical test:**

IEC 61000-4-2	level III
IEC 61000-4-4	level III
IEC 61000-4-5	level III
IEC 61010-1	AC2kV/1min Between power / input / output

**Product standards**

---

GB / T 14048.1 (IEC 60947-1)	Low-voltage switchgear and control equipment General Provisions
GB / T 14048.4 (IEC 60947-4)	Low voltage electromechanical contactors and motor starters requirements
JB / T 10613-2006	General specification for digital motor combined protection equipment
JB / T 10736-2007	Low voltage motor protection

---

**Product selection guide**

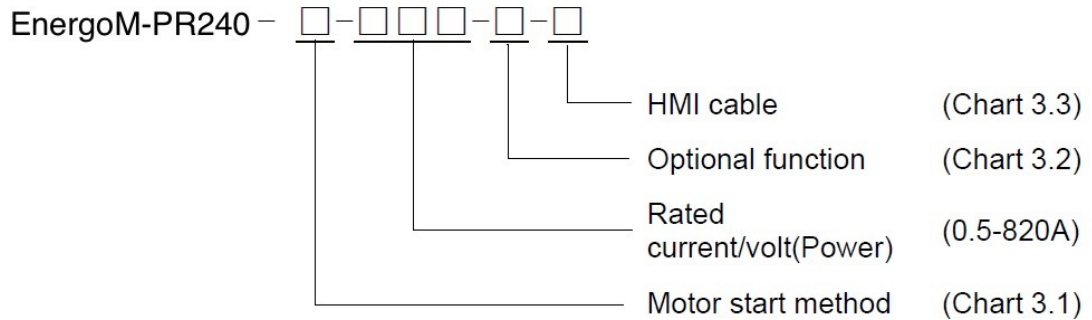

SN	Preset Motor Start method	Code
1	Protect only	A
2	Full voltage	B
3	Forward and reverse start	C
4	Two-Winding start	S
5	Wye-Delta Transition	D
6	Autotransformer Closed Transition	G

Chart 3.1

SN	Optional function	Code
1	With Zero sequence CT	L
2	4 ~ 20mA analog port	M
3	Temperature probe	T
4	SOE record	R

**Notes:** Standard type without additional function, If need multiple additional functions the coded arranged in sequence after main code.

Chart 3.2

HMI cable length	Code
1-meter cable	D1
3-meters cable	D3
3-meters cable	D5

Chart 3.3

**External protection CT selection guide, typical in 380V grid:**

Motor rated power (Kw)	Rated current (A)	Internal CT range
0.06	0.22	10A
0.12	0.42	
0.37	1	
0.55	1.5	
0.75	2	
1.1	2.5	
2.2	5	
3	6.5	
5.5	11	100A
7.5	14.8	
11	21	
15	28.5	
18.5	35	
22	42	
30	57	
37	69	
45	81	
55	100	

Motor rated power (Kw)	Rated current (A)	Internal CT	External CT
<b>75</b>	<b>135</b>	10A	500/5
90	165		
110	200		
132	240		
160	285		
200	352		
220	420		
250	480		

**Notes:** If motor rated current over 100A, need to connect an external CT, suggest use 500/5A CT. In Configuration menu-[CT ratio] set to 100.(See chapter 5.6.2)



**Residual current sensor**

If EnergoM-PR240 choose ground fault protection, need external LCT05/30 series CT for detect leakage current.

LCT05 rated current of 500mA, the current range (50 ~ 500mA)

LCT30 rated current of 30A, the current range of (3 ~ 30A)

Each EnergoM-PR240 need 1pcs, please contact sales team for purchase issue.

**Wiring core for cable type**

Current range	Dimension (mm)								
	φ	A	B	C	D	E	F	G	H
16-100A	45	77	85	24	38	54	9	64	54
100-250A	80	112	122	28	56	80	14	89	80
250-400A	100	131	136	24	66	96	14	108	107
400-800A	150	200	209	28	100	145	16	184	177

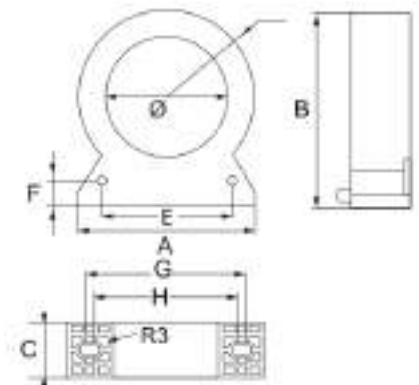

**Wiring core for cooper bar type**

Current range	Dimension (mm)								
	A1	B1	A	B	C	D	E	F	G
0-63A	100	20	133	50	16	144	140	3	2.0
0-100A	100	25	133	60	24	154	143	9	2.5
0-225A	140	32	172	72	24	189	184	9	2.5
0-250A	180	32	212	72	24	229	224	9	2.5
0-400A	220	45	254	86	24	269	264	11	2.5
0-630A	260	45	294	86	24	309	304	11	2.5
0-1600A	300	45	334	86	24	349	344	11	2.5
0-4000A	420	45	454	86	24	469	464	11	2.5

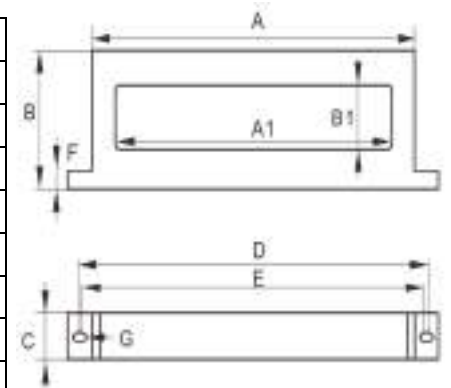

**Notes:** Protection function please refer *Chapter 7.7*

## 4.- INSTALLATION AND START-UP



The manual you hold in your hand contains information and warnings that the user should respect in order to guarantee a proper operation of all the instrument functions and keep it in safety conditions. The instrument must not be powered on and used until its definitive assembly is on the cabinet's door.

**If the instrument is not used as manufacturer's specifications, the protection of the instrument will be damaged.**

When any protection failure is suspected to exist (for example, it presents external visible damages), the instrument must be immediately powered off. In this case contact a qualified service representative.

### 4.1.- Installation

#### Mounting

Energom-PR240 series motor protection relay designed as separate 2 parts, one for din-rail mounting body, another is panel mounting HMI.

Note that with the instrument powered on, the terminals could be dangerous to touch and cover opening actions or elements removal may allow accessing dangerous parts. Therefore, the instrument must not be used until this is completely installed.

**Note:** This connection drawing is for reference only; the actual connecting terminal please refer to the label on the rear part.

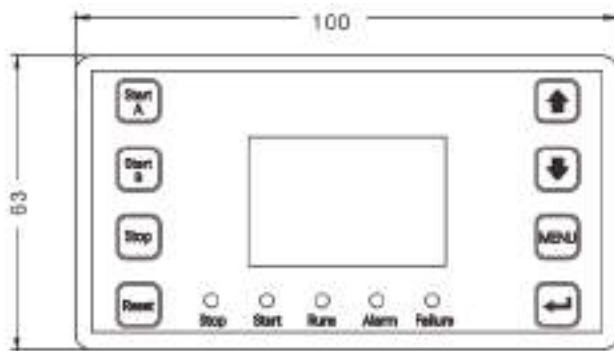
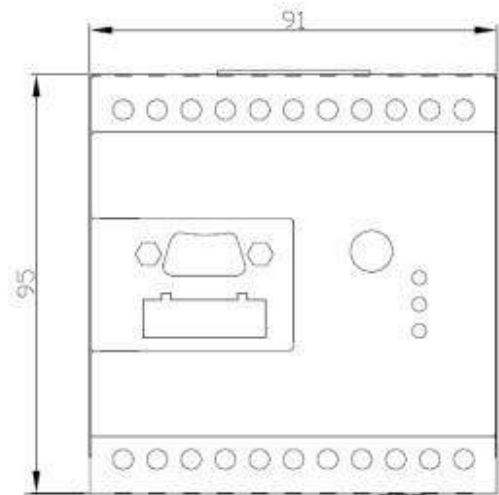
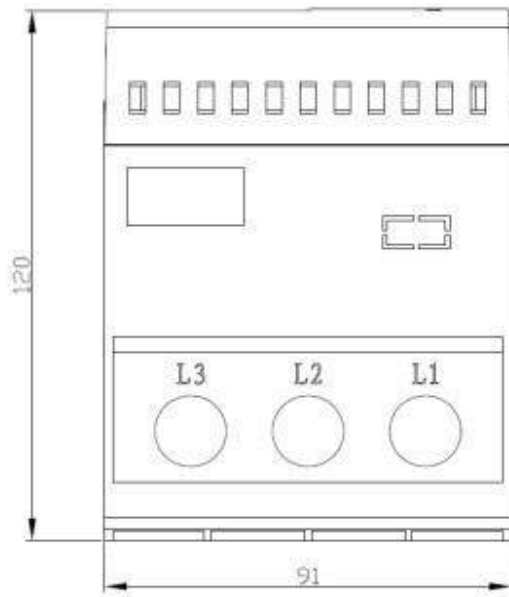

Top View

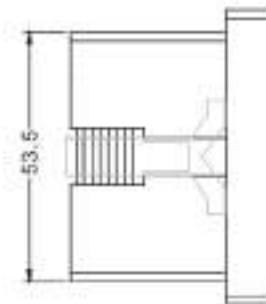

Side View

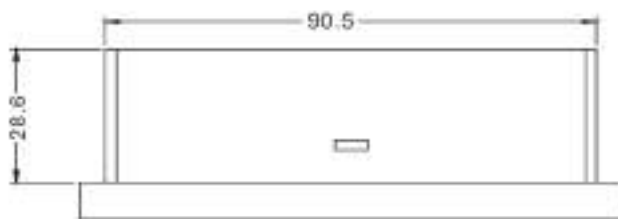

Front View

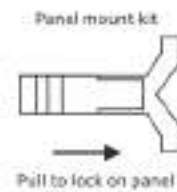

### 4.1.- Terminal Definition

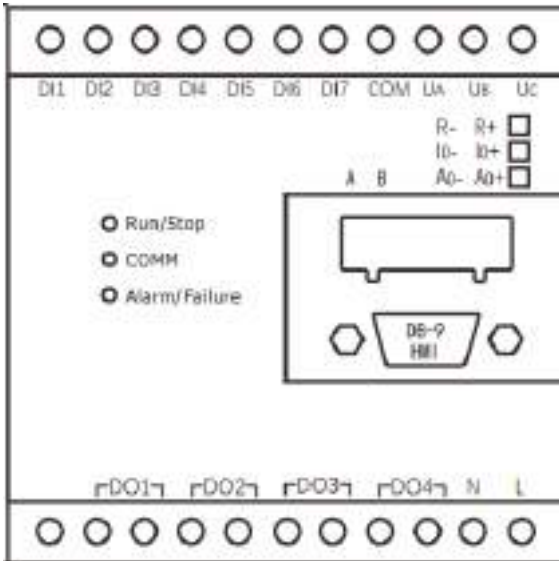

LED indicator Introduction

#### Run/Stop:

Always ON when motor stopped;  
Flicker when motor running.

#### COMM:

Flicker when RX/TX.

#### Alarm/Failure

Always ON when device have failure;  
Flicker when motor in alarm threshold triggered.

#### Notes:

1. EnergoM-PR240 provide 7 digital input terminals, external signal sampling interval  $\geq 100$ ms. 15Vdc
2. Digital feedback external NO/NC controlled by passive contacts.
3. EnergoM-PR240 provide 4 relay outputs, DO status can be set in NO or NC, support Level output or Pulse output.

#### Caution:

1. Forbidden to connect external feed voltage to DI terminals!
2. Do not wire the DI terminal in the same tube or twist it with high voltage cable!
3. If distance more than 2 meters must use shielded cable! The maximum distance of the DI pinout should not exceed 300 meters!

#### Terminal defecation

Terminal No.	Description
11	A-phase voltage
12	B-phase voltage
13	C-phase voltage
4	A-phase current
6	B-phase current
8	C-phase current
10	Zero sequence current input
42	Leakage current input+
43	Leakage current input-
44	NTC -
45	NTC +
58	RS485A
59	RS485B
19-20	DO1

21-22	DO2	
23-24	DO3	
25-26	DO4	
15	4~20 mA-	
16	4~20mA +	
70	DI COM Terminal	
71	DI 1	
72	DI 2	
73	DI 3	
74	DI 4	
75	DI 5	
76	DI 6	
77	DI 7	
1	Aux - L	90~240Vac/dc
2	Aux - N	

## 5. OPERATION MODE



Energom-PR240 have a HMI, wired to relay body by DB9 cable;

It used for parameter display and configuration, also can use operation button to control motor working or stop.

LED indicator show motor status.

### 5.1- LCD display screen











Screen area adopts a large size dot-matrix LCD, backlight is gray. The backlight time free to configuration. When there is a key operation, the backlight will be re-lit, and will go out after the set interval.

After device be powered, HMI default screen is measurement interface. In this interface, pressing

the "  " button can enter password and switch to configuration interface.

In this configuration menu, user can set the protection mode, system parameter, view fault alarm record, operation information etc.

### 5.2- Panel LED Indicator

Indicator mark	Description
Stop	 Motor in working status
	 Motor stopped
Start	 Motor in non-start status
	 Motor in starting period
Runs	 Motor in non-runs status
	 Motor in running
Alarm	 Motor in normal status
	 Alarm threshold triggered
Failure	 DO in non-trip status
	 DO tripped

### 5.3- Motor Control Buttons

There have 4 key buttons for motor operation:

	Local direct control	Under remote control mode
In "Protect only" mode	Invalid	
In "Panel control start/stop" mode	Motor start	Invalid
In "Forward and reverse start" mode	Motor start in forward rotation	Invalid
In "Two-Winding start" mode	Motor start in low winding-1(low speed)	Invalid
In "Wye-Delta Transition" mode	Motor start	Invalid
In "Autotransformer Closed Transition" mode	Motor start	Invalid





	Local direct control	Under remote control mode
In "Protect only" mode	Invalid	
In "Panel control start/stop" mode	Motor start	Invalid
In "Forward and reverse start" mode	Motor start in reverse rotation	Invalid
In "Two-Winding start" mode	Motor start in low winding-2(high speed)	Invalid
In "Wye-Delta Transition" mode	Invalid	Invalid
In "Autotransformer Closed Transition" mode	Invalid	Invalid

	Local direct control	Under remote control mode
In "Protect only" mode	Invalid	
In "Panel control start/stop" mode	Stop motor immediately	Invalid
In "Forward and reverse start" mode	Stop motor immediately	Invalid
In "Two-Winding start" mode	Stop motor immediately	Invalid
In "Wye-Delta Transition" mode	Stop motor immediately	Invalid
In "Autotransformer Closed Transition" mode	Stop motor immediately	Invalid

	Press to release alarm and reset DO port to non-tripped status when motor in <b>Stopped</b> status.
---	---



### 5.4- Configuration Buttons

In HMI right are have 4 buttons for configuration operations:

	<p>Under measurement interface: Switch to former parameter displayed. Under configuration interface: Move cursor to left and increase value.</p>
	<p>Under measurement interface: Switch to next parameter displayed. Under configuration interface: Move cursor to right and decrease value.</p>
	<p>Under measurement interface: Switch to configuration interface (password requested). Under configuration interface: Exit or switch to measurement interface.</p>
	<p>Confirmed the enter value or setting changes.</p>

#### 5.4.1- Enter configuration menu

In normal monitor status, press , screen will ask Password,



Press  into password screen, use  and  to enter password

**Notes:** Default user password is 0001),

Then press key  to confirm enter, in password correct can into the menu screen,

**Notes:** If password changed and enter error, screen still ask password again.

#### 5.4.2- Exit configuration menu

After parameter set, press , protector screen show "SAVE", then press  for save the

change and exit, press key  for exit without save.

**5.5- Measurement Interface**

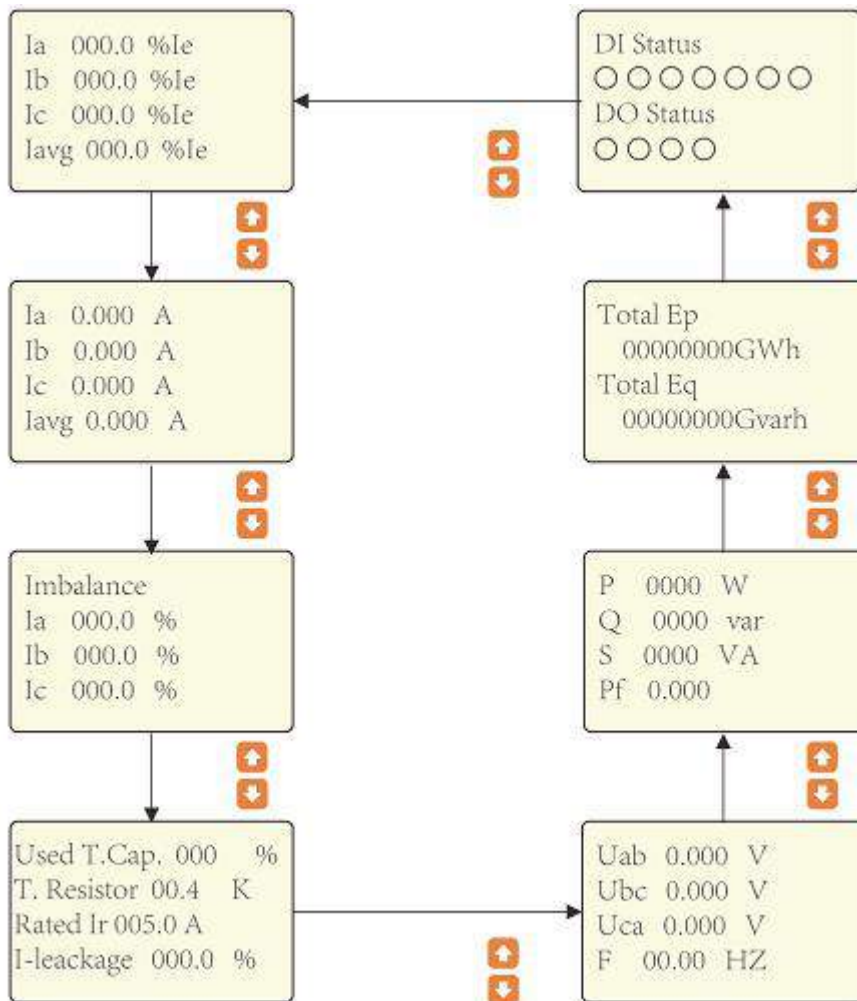

**Notes:**

1. Thermal resistance parameter is only valid when access temperature probe;
2. Symbol of DI/DO status:  
 Hollow circle means no digital input or no relay triggered;  
 Solid circle means digital signal looped in or relay be triggered;
3. When the measured current > 1.3 \* Protect CT, the display value of measurement error will be increasing.
4. Press Enter button can switch to Motor status screen:

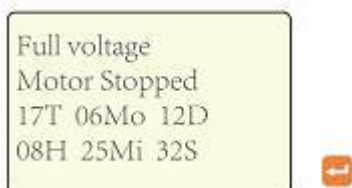



**5.6- Configuration Menu**

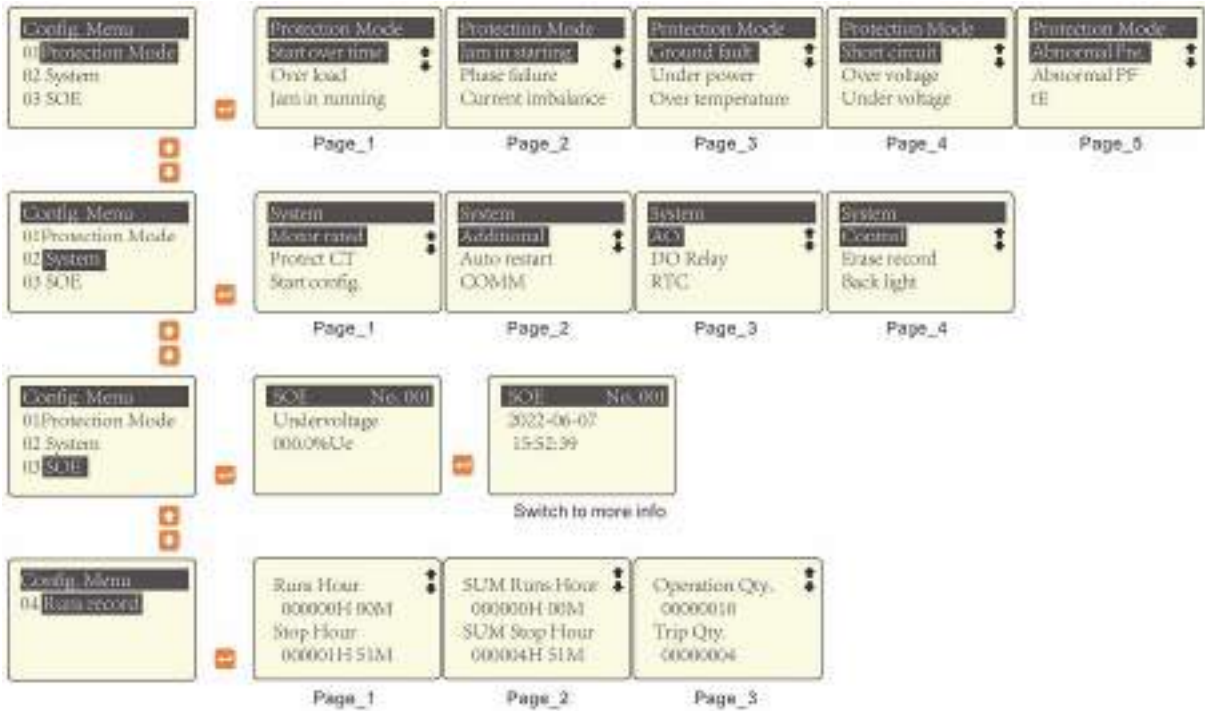

**5.6.1- Protection mode configuration**

There have 15 different protection mode can configuration, detail function descriptions please refer to **Chapter 7**:

Start over time (chapter 7.1):

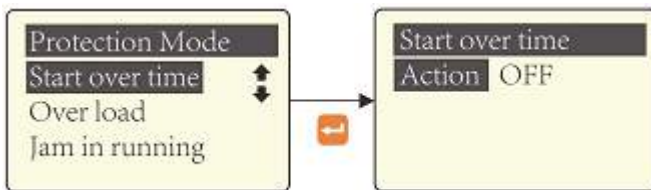

Over time (chapter 7.2):

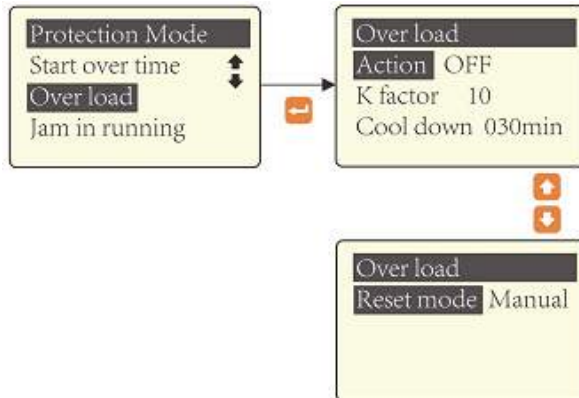

Jam in running (chapter 7.3):

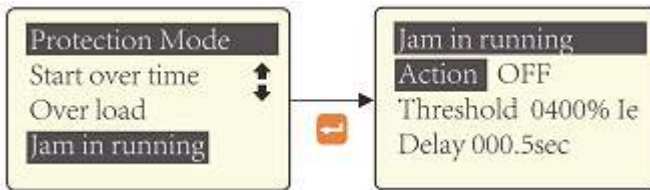

Jam in running (chapter 7.4):

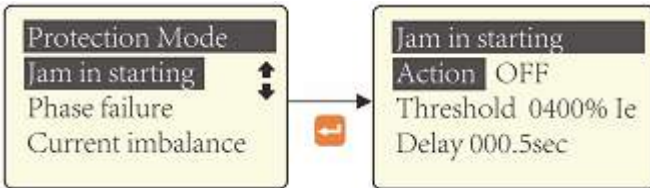

Phase failure (chapter 7.5)

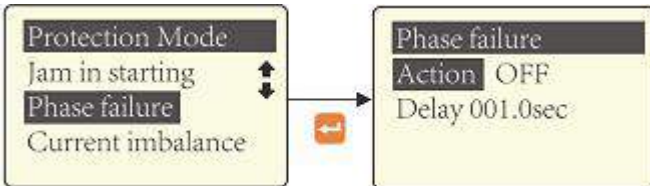

Current imbalance (chapter 7.6)

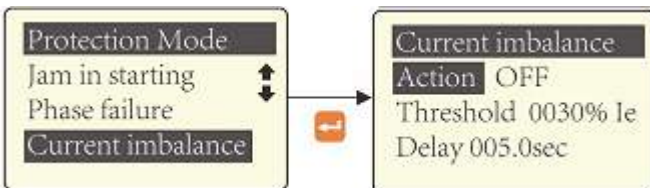

Ground fault (chapter 7.7)

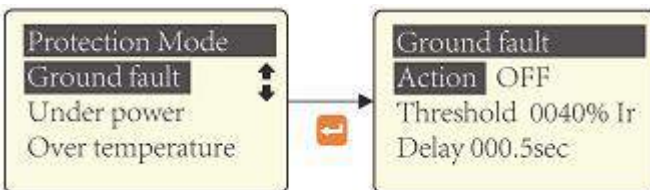

Under power (chapter 7.8)

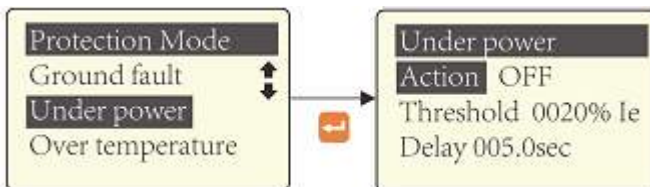

Over temperature (chapter 7.9)

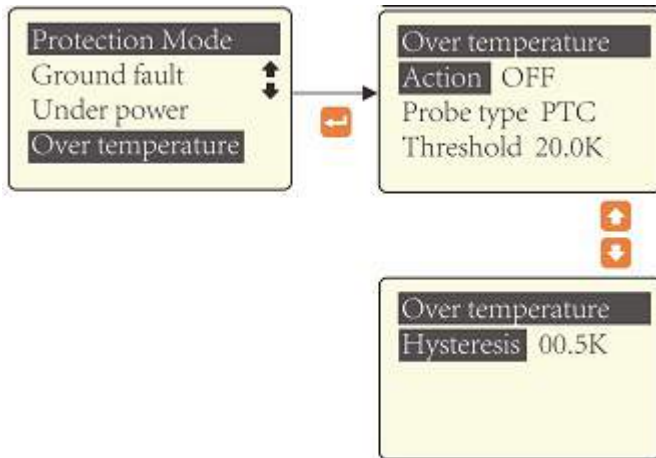

Short circuit (chapter 7.10)

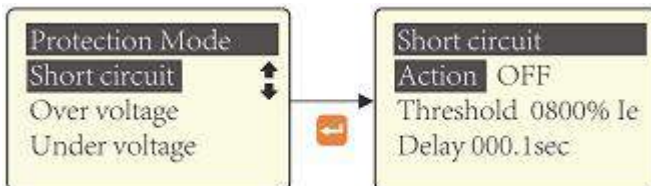

Over voltage (chapter 7.11)



Under voltage (chapter 7.12)

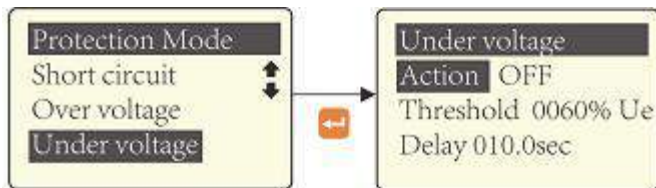

Abnormal Frequency (chapter 7.13)

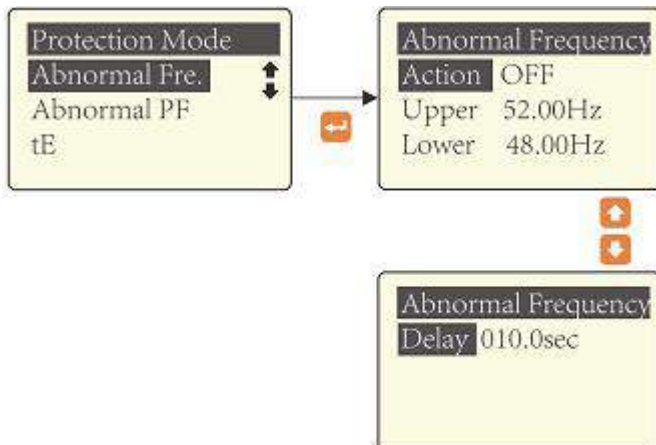

Abnormal Power factory (chapter 7.14)

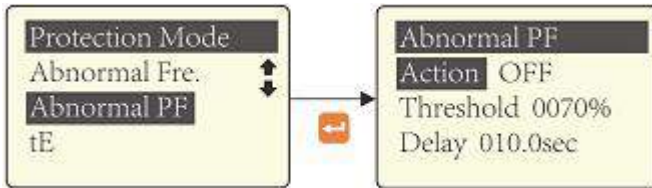

tE protection (chapter 7.15)

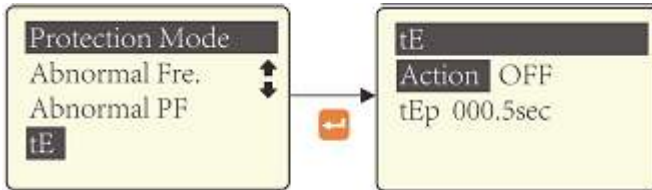

**5.6.2- System parameter- configuration**

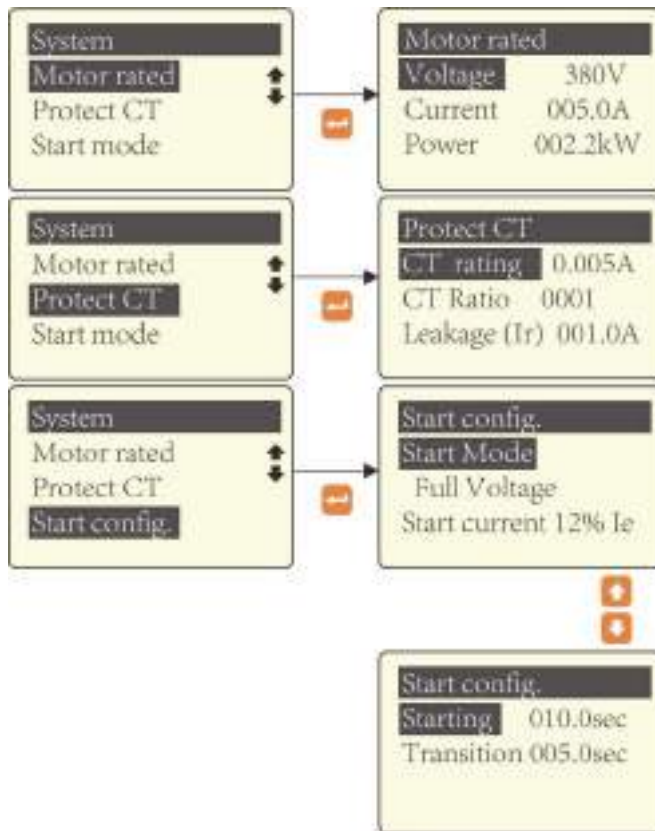

**Notes:** Rated Current ( $I_e$ ) already set in factory. This screen value only accepts fine-tuning to suit different site.  
**Caution:** If wrong setting will make trip time point error and damage Motor!

**Notes:** CT rating only valid in situation  $I_e > 100A$ ;  
If used  $I_e < 100A$ , CT rating is factor default configuration, no need to change. CT ratio always set 0001.

**Notes:** Details see **Chapter 8**

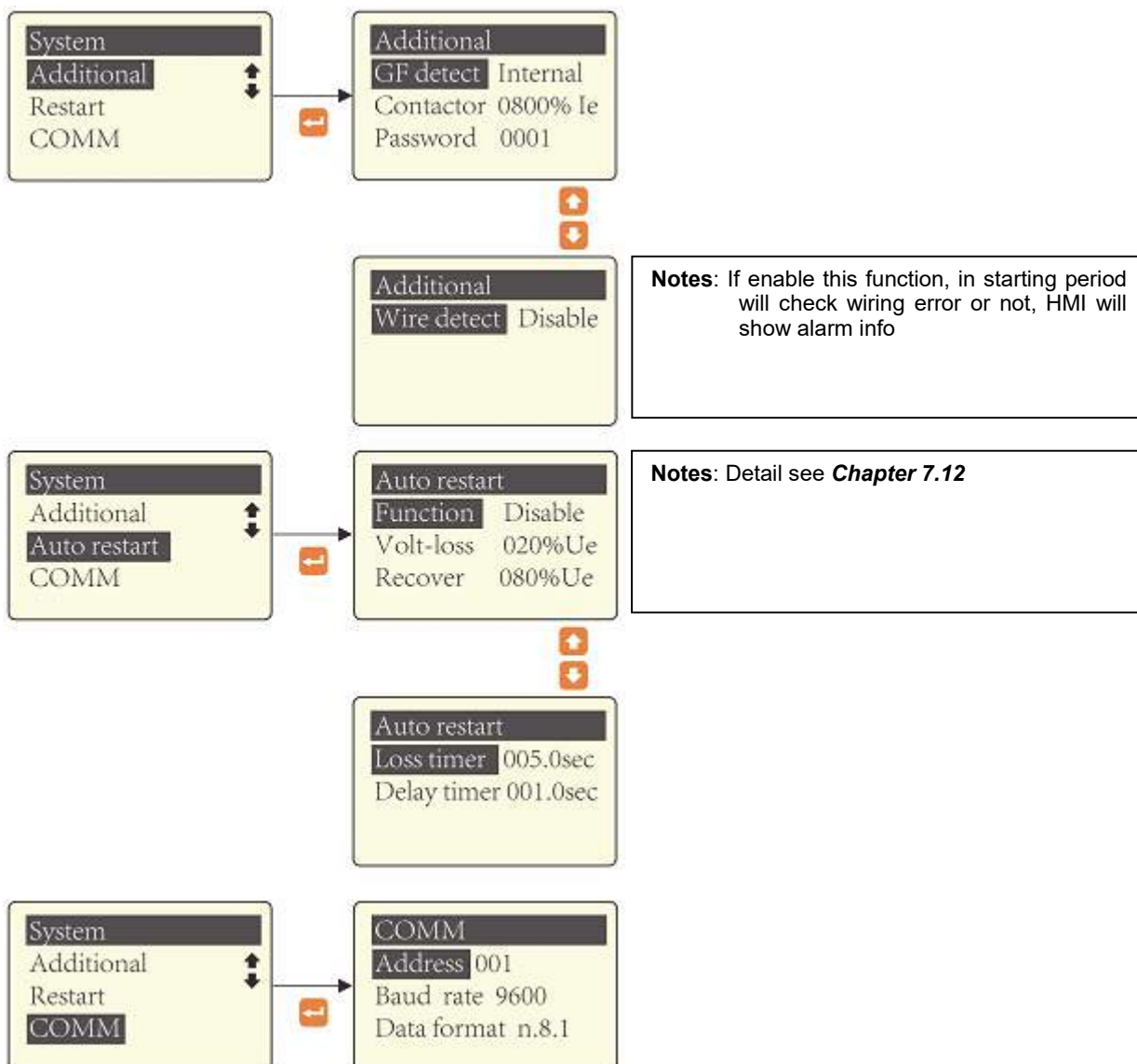



**Notes:** This screen is for calibration use, already calibrated in factory. User no need to extra calibrate again.  
**Caution:** If need to re-calibrate, please contact technical team to get admin password.

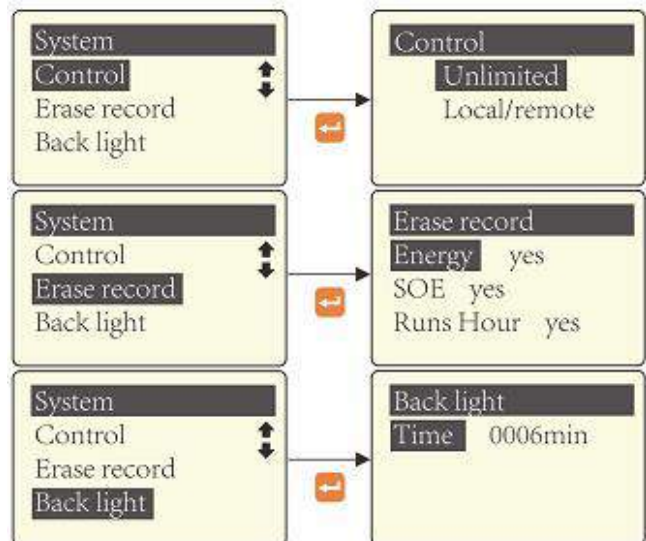
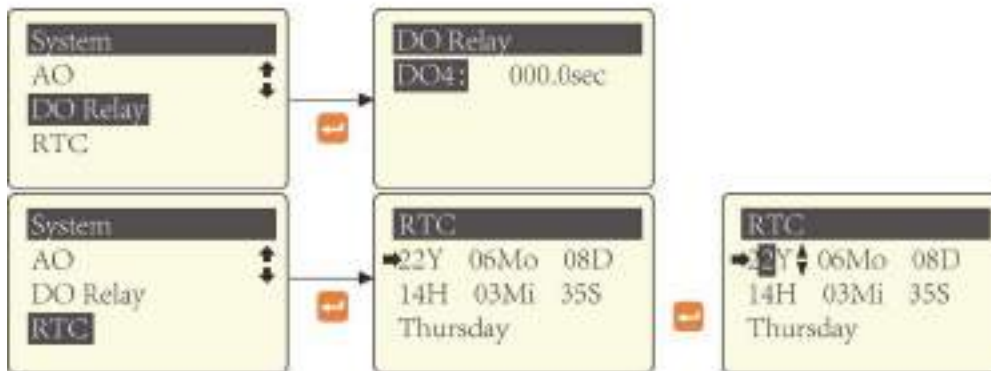

## 6. - RS485 COMMUNICATION PORTOCOL

### 6.1.- MODBUS © protocol

The composition of the RS-485 cabling must be carried out with a meshed screen cable (minimum 3 wire), diameter of not less than 0.5mm<sup>2</sup>, with a maximum distance of 1,200 m between the motor protector and the master unit. This Bus may connect a maximum of 32unit.

#### Notes:

1. For communication with the master unit, customers can choose the RS-232 to RS-485 converter to use.
2. Not all the EnergoM-PR240 series have RS485 full operation function, please check your ordered product to confirm whether has related function. If products no response when read/write some register, mostly not equipped that functions.

Due to product modifications or custom requirements, the interface pin place may be change. For details, please refer to product label on the rear board

#### 6.1.1- Modbus RTU Frame Format:

<b>Address code</b>	<b>1 BYTE</b>	<i>Slave device address 1-247</i>
<b>Function code</b>	<b>1 BYTE</b>	<i>Indicates the function codes like read coils / inputs</i>
<b>Data code</b>	<b>4 BYTE</b>	<i>Starting address, high byte Starting address, low byte Number of registers, high byte Number of registers, low byte</i>
<b>Error Check code</b>	<b>2 BYTE</b>	<i>Cyclical Redundancy Check (CRC)</i>



### 6.1.2.- Modbus function code

<b>Code:</b>	<b>Meaning:</b>	<b>Description:</b>
<b>FUNCTION 01</b>	Read multiple Coils	<i>This function permits to read Internal Bits or Physical Coils</i>
<b>FUNCTION 02</b>	Read signal Coils	<i>This function permits to read Physical Discrete Inputs</i>
<b>FUNCTION 03</b>	Reading of n Words of holding register	<i>Read protection setting, system parameters, starting parameters, etc. Read the I/O port status</i>
<b>FUNCTION 04</b>	Reading of n Words of input register	<i>Read measurement values (voltage, current, power, etc.); Read SOE record</i>
<b>FUNCTION 05</b>	Force Single Coil	<i>This function permits to write Internal Bits or Physical Coils</i>
<b>FUNCTION 06</b>	Write single register	<i>This function permits to write</i>

**Example\_1: Read A, B, C phase current value**

Host to Slave

MODBUS ID	Func.	Data Address (high)	Data Address (low)	Data Number (high)	Data number (low)	CRC16 (low)	CRC16 (high)
01H	04H	00H	00H	00H	03H	BEH	F7H

Slave to Host

MOBUDS ID	Func.	Data length	A-phase current		B-phase current		C-phase current		CRC	
01	04	06	03	E8	03	E8	03	E7	C0	7D

**Example\_2: Write motor rated current from 1A to 1.5A**

Host to Slave

MODBUS ID	Func.	Data Address (high)	Data Address (low)	Data Value (high)	Data Value (low)	CRC	
01	06	02	05	00	0F	80	7E

Slave to Host

MODBUS ID	Func.	Data Address (high)	Data Address (low)	Data Value (high)	Data Value (low)	CRC	
01	06	02	05	00	0F	80	7E

**Example\_3: MODBUS command control relay to trigged**

Host to Slave

MODBUS ID	Func.	Data Address (high)	Data Address (low)	Data Value (high)	Data Value (low)	CRC	
01	05	00	01	FF	00	DD	DA

Slave to Host

MODBUS ID	Func.	Data Address (high)	Data Address (low)	Data Value (high)	Data Value (low)	CRC	
01	05	00	01	FF	00	DD	DA

**6.2.- Motor Status Parameter (Read Only, code 04)**

Address	Parameter	Description
0x00	A-phase Current	Unit: 0.1A
0x01	B-phase Current	
0x02	C-phase Current	
0x03	AB line voltage	Unit: 0.1V
0x04	BC line voltage	
0x05	CA line voltage	
0x06	Active power (Ps_avg)	Unit: 0.1KW
0x07	Reactive power (Qs_avg)	Unit: 0.1KVar
0x08	Apparent power (Ss_avg)	Unit: 0.1KVA
0x09	Power factor	Unit: 0.001
0x0A	Frequency	Unit: 0.01Hz
0x0B	Residual current	Unit: 0.1mA
0x0C	Thermal resistance	Range: 100-30000Ω
0x0D	Used thermal capacity (UTC)	Range: 0-100%
0x12	Digital input status	0: without signal 1: With signal in BIT0:DI1 BIT1:DI2 BIT2:DI3 BIT3:DI4 BIT4:DI5 BIT5:DI6 BIT6:DI7
0x13	Digital output status	0: Opened 1: Closed BIT0:DO1 BIT1:DO2 BIT2:DO3 BIT3:DO4
0x14	A-Phase current percentage	Unit: 0.1%
0x15	B-Phase current percentage	Unit: 0.1%
0x16	C-Phase current percentage	Unit: 0.1%
0x17	AB line voltage percentage	Unit: 0.1%
0x18	BC line voltage percentage	Unit: 0.1%
0x19	CA line voltage percentage	Unit: 0.1%
0x1A	Active power percentage	Unit: 0.1%
0x1B	Reactive power percentage	Unit: 0.1%
0x1C	Apparent power percentage	Unit: 0.1%
0x1D	Power factor percentage	Unit: 0.1%
0x1E	Frequency percentage	Unit: 0.1%
0x1F	Residual current percentage (External)	Unit: 0.1% Sampling from external zero-sequence sensor
0x20	Residual current percentage (Internal)	Unit: 0.1% Calculated from fundamental frequency

0x23	Average voltage percentage	Unit: 0.1%
0x24	Average current percentage	Unit: 0.1%
0x25	Peak voltage percentage	Unit: 0.1%
0x26	Peak current percentage	Unit: 0.1%
0x28	A-phase current imbalance	Unit: 0.1%
0x29	B-phase current imbalance	Unit: 0.1%
0x2A	C-phase current imbalance	Unit: 0.1%
0x32-0x35	Active energy (Ep)	Unit: 1WH
0x36-0x39	Reactive energy (Eq)	Unit: 1varH
0x48	Device present state	0: Waiting for delay timer 1: Start standby 2: Starting 3: Running 4: Stopped 5: Stopped by failure trip
0x49	Device present alarm type	0x0000: No alarm 0x0001: Start Overtime 0x0002: Over Load 0x0004: Phase Failure 0x0008: Jam in starting 0x0010: Current imbalance 0x0020: Under power 0x0040: Jam in running 0x0080: Ground fault 0x0100: tE protection 0x0200: Over voltage 0x0400: Under voltage 0x0800: Abnormal frequency 0x1000: Abnormal power factor 0x2000: Over temperature 0x4000: Short circuit
0x4A	Device present failure type	0x0000: No alarm 0x0001: Start Overtime 0x0002: Over Load 0x0004: Phase Failure 0x0008: Jam in starting 0x0010: Current imbalance 0x0020: Under power 0x0040: Jam in running 0x0080: Ground fault 0x0100: tE protection 0x0200: Over voltage 0x0400: Under voltage 0x0800: Abnormal frequency 0x1000: Abnormal power factor 0x2000: Over temperature 0x4000: Short circuit
0x4B	Present run hours (Lower 16 bits)	Unit: Second
0x4C	Present run hours (High 16 bits)	
0x4D	Present stopped hours (Lower 16 bits)	Unit: Second
0x4E	Present stopped hours (High 16 bits)	
0x4F	Total run hours (Lower 16 bits)	Unit: Second
0x50	Total run hours (High 16 bits)	
0x51	Total stopped hours (Lower 16 bits)	Unit: Second
0x52	Total stopped hours (High 16 bits)	

0x53	Total operation times(Lower 16 bits)	Unit: times
0x54	Total operation times(High 16 bits)	
0x55	Total tipped number(Low 16 bits)	Unit: times
0x56	Total tipped number(High 16 bits)	
0x64	Year	RTC info
0x65	Month	
0x66	Date	
0x67	Hour	
0x68	Minute	
0x69	Second	
0x6A	Week	

### 6.3.- Motor Basic Configuration (Read and write)

#### Cautions!

1. This chapter register map in default products the write function is disable in standard EnergoM-PR240,  
that to avoid unexpected damage due to frequent write operations, only opened for customer requirement!!
2. Registers support maximum 100,000 times writes, wrong write registers may cause device irreparable damage! Please ensure that host software engineer proficient in RS485 MODBUS protocol.
3. When the customer request valid the register write function,. will not responsible for any damage caused by the register write operation!!

Address	Contents	Description
0x200	Password	Range: 1-9999
0x201	External CT rating	Range: 1-9999 (real value 0.1-999.9 A)
0x202	CT ratio	Range: 1-9999
0x203	Leakage current transformer rating (I <sub>r</sub> )	Range: 1-9999 (real value 0.1-999.9 A)
0x204	Motor rated voltage	Range: 0-690
0x205	Motor rated current (I <sub>e</sub> )	Range: 1-9999 (real value 0.1-999.9 A)
0x206	MODBUS ID	Range: 1~247
0x207	Baud ratio	0:2400 1:4800 2:9600 3:19200
0x208	Data format	0: n.8.1 1: o.8.1 2: e.8.1 3: n.8.2
0x209	Reserved	/
0x20A	Ground fault detect mode	0: Internal Calculated from fundamental frequency component 1: External Sampling from external zero-sequence sensor
0x20B	Auto restart	0: Disable 1: Enable
0x20C	Voltage loss threshold	Range: 50 ~100%U <sub>e</sub>
0x20D	Voltage recovered threshold	Range: 50 ~100%U <sub>e</sub>
0x20E	Voltage loss timer	Range: 0.1-60.0sec
0x20F	Restart delay timer	Range: 0.1-60.0sec
0x210	Motor rated power	unit KW

#### 6.4.- Motor Protection Functions Configuration (Read and write)

##### Cautions!

1. This chapter register map in default products the write function is disable in standard EnergoM-PR240,  
that to avoid unexpected damage due to frequent write operations, only opened for customer requirement!!
2. Registers support maximum 100,000 times writes, wrong write registers may cause device irreparable damage! Please ensure that host software engineer proficient in RS485 MODBUS protocol.
3. When the customer request valid the register write function,. will not responsible for any damage caused by the register write operation!!

Address	Contents	Description	
0x300	Start Overtime protect action	Chapter 7.1	0: Invalid 1: Alarm 2: Trig DO
0x301	Over Load protect action	Chapter 7.2	0: Invalid 1: Alarm 2: Trig DO
0x302	Over Load K factor		0: K=10 1: K=25 2: K=60 3: K=75 4: K=100 5: K=125 6: K=250 7: K=300 8: K=500 9: K=750 10: K=1000 11: K=1200
0x303	Over Load protection cool down timer		Range: 1-1200min
0x304	Over Load reset method		0: Manual 1: Automatic
0x305	Jam in running protect action		0: Invalid 1: Alarm 2: Trig DO
0x306	Jam in running protect threshold	Chapter 7.3	Range: 100-1000% Ie
0x307	Jam in running protect timer		Range: 0.5-50.0sec
0x308	Contactor breaking current		Range: 100-1000% Ie
0x309	Jam in starting protect action	Chapter 7.4	0: Invalid 1: Alarm 2: Trig DO
0x30A	Jam in starting protect threshold		Range: 100-1000% Ie
0x30B	Jam in starting protect timer		Range: 0.5-50.0sec
0x30C	Phase failure protect action	Chapter 7.5	0: Invalid 1: Alarm 2: Trig DO
0x30D	Reserved		
0x30E	Phase failure protect timer		Range: 0.1-50.0sec
0x30F	Current imbalance protect action	Chapter 7.6	0: Invalid 1: Alarm 2: Trig DO
0x310	Current imbalance threshold		Range: 5-60%
0x311	Current imbalance protect timer		Range: 0.1-50.0sec
0x312	Ground fault protect action	Chapter 7.7	0: Invalid 1: Alarm 2: Trig DO
0x313	Ground fault protect threshold		Range: 10-100% Ir

0x314	Ground fault protect timer		Range: 0.1-50.0sec
0x315	Under power protect action	Chapter 7.8	0: Invalid 1: Alarm 2: Trig DO
0x316	Under power protect threshold		20-100% Ie
0x317	Under power protect timer		Range: 0.5-60.0sec
0x318	Over temperature protect action	Chapter 7.9	0: Invalid 1: Alarm 2: Trig DO
0x319	Temperature probe type		0: PTC 1: NTC
0x31A	Over temperature trig threshold		Range: 0.1 ~ 30.0KΩ
0x31B	Over temperature recover hysteresis		Range: 0.1 ~ 30.0KΩ
0x31C	Short circuit protect action	Chapter 7.10	0: Invalid 1: Alarm 2: Trig DO
0x31D	Short circuit protect threshold		Range: 100-1000% Ie
0x31E	Short circuit protect timer		Range: 0.1-50.0sec
0x31F	Over voltage protect action	Chapter 7.11	0: Invalid 1: Alarm 2: Trig DO
0x320	Over voltage protect threshold		Range: 105-150% Ue
0x321	Over voltage protect timer		Range: 0.1-50.0sec
0x322	Under voltage protect action	Chapter 7.12	0: Invalid 1: Alarm 2: Trig DO
0x323	Under voltage protect threshold		Range: 50-95% Ue
0x324	Under voltage protect timer		Range: 0.1-50.0sec
0x325	Abnormal frequency protect action	Chapter 7.13	0: Invalid 1: Alarm 2: Trig DO
0x326	Frequency protect upper threshold		Range: 50.00-55.00 Hz
0x327	Frequency protect lower threshold		Range: 45.00-50.00 Hz
0x328	Frequency protect timer		Range: 0.1-50.0sec
0x329	Abnormal power factor protect action	Chapter 7.14	0: Invalid 1: Alarm 2: Trig DO
0x32A	Power factor protect threshold		Range: 20-95%
0x32B	Power factor protect timer		Range: 1.0-60.0sec
0x32C	Reserved		
0x32D	tE protect action	Chapter 7.15	0: Invalid 1: Alarm 2: Trig DO
0x32E	tE protect value		Range: 1.0~15.0sec



### 6.5.- Motor Start Mode Configuration (Read and write)

#### Cautions!

1. This chapter register map in default products the write function is disable in standard EnergoM-PR240,  
that to avoid unexpected damage due to frequent write operations, only opened for customer requirement!!
2. Registers support maximum 100,000 times writes, wrong write registers may cause device irreparable damage! Please ensure that host software engineer proficient in RS485 MODBUS protocol.
3. When the customer request valid the register write function, . will not responsible for any damage caused by the register write operation!!

Address	Contents	Description
0x32F	Motor starting timer	Range: 1.0~600.0sec
0x330	Transition timer	Range: 1.0~600.0sec
0x331	Motor starting current	Range: 5%~20%
0x332	Control switch permissions	0: Unlimited - all control methods are valid 1: Local/remote: DI3 closed for HMI panel control; DI3 opened for external control loop (DO or MODBUS command) control. <b>Notes:</b> Factory default set "0"
0x333	Motor start mode	0: Only protection 1: Full voltage 2: Forward / reverse 3: Two-Winding 4: Voltage loss restart 5: Wye-Delta Transition 6: Autotransformer Closed Transition 7: MCB direct start
0x334-0x335	Reserved	
0x336	Start Wiring Check Enable	0: Disable 1: Enable
0x337-0x33F	Reserved	
0x340	AO output zero span(0mA)	Default 0.0%
0x341	AO output full span(20mA)	Default 100.0%
0x342	AO output selection	0: 0-20mA 1: 4-20mA
0x343	AO transmit parameters	0: I1                      6: Ps 1: I2                      7: Qs 2: I3                      8: Ss 3: U1                      9: Pf 4: U2                      10: Fr 5: U3
0x344-0x348	Reserved	
0x349	DO4	Trip Circuit Breaker when short circuit protection. Export pulse signal to MCB, refer to <b>chapter 7.10</b>  Range: 0-999.9Sec 0 for level control

**6.5.- Sequence of Event Record (Read Only, code 04)**

Address	Contents	Description
0x500-0x504	SOE_001	SOE_001 is latest record Details see Notes
0x505-0x509	SOE_002	
0x50A-0x50E	SOE_003	
0x50F-0x513	SOE_004	
0x514-0x518	SOE_005	
0x519-0x51D	SOE_006	
...	...	
0x6EF-0x6F3	SOE_100	

**Notes:** Each event is represented by 10 bytes.

BYTE 0-1 for failure type	01: Start Overtime	06: Under power	11: Under voltage
	02: Over Load	07: Jam in running	12: Abnormal frequency
	03: Phase Failure	08: Ground fault	13: Abnormal power factor
	04: Jam in starting	09: tE protection	14: Over temperature
	05: Current imbalance	10: Over voltage	15: Short circuit
BYTE 2-3	Failure value		
BYTE 4-9	Failure event timestamp		
BYTE 4	Year		
BYTE 5	Month		
BYTE 6	Date		
BYTE 7	Hour		
BYTE 8	Minute		
BYTE 9	Second		

### 6.5.- Motor Advanced Control (Read and write)

#### Cautions!

1. This chapter register map in default products the write function is disable in standard EnergoM-PR240,  
that to avoid unexpected damage due to frequent write operations, only opened for customer requirement!!
2. Registers support maximum 100,000 times writes, wrong write registers may cause device irreparable damage! Please ensure that host software engineer proficient in RS485 MODBUS protocol.
4. When the customer request valid the register write function, will not responsible for any damage caused by the register write operation!!

Address	Contents	Description
0x800	Clear SOE log	Writ in code: <b>0A0A</b>
0xD00	Remote command control motor	<b>Reset</b> 0x10 <b>Stop</b> 0x20 <b>Start B</b> 0x40 <b>Start A</b> 0x80
0xF00	Reset energy counter	Writ in code: <b>0A0A</b>

## 7.- PROTECTION FUNCTION INTRODUCTION

### 7.1- Start Overtime Protection

Start overtime protection provides protection of motor during starting period. After motor in regular running period, start overtime protection will automatically exit.

Protective action logic:

After Start timer countdown to 0, either of the following two condition will trig protect action.

1. Three-phase average current  $\geq 1.1$  times the motor rated current (Ie) **OR**
2. Three-phase average current  $\leq 10\%$  of the motor rated current (Ie)

Protect action	OFF / Alarm / Trig DO
Start timer <sup>(1)</sup>	1.0 ~ 600.0s
Action delay	0

(1) Start time can be set in HMI configuration menu, or register 0x32FH

## **7.2- Overload Protection**

Device can calculate used thermal capacity (UTC) of the motor to avoid motor from overheating damage. Internal program simulates the used thermal capacity of the motor in a variety of operating conditions, can real-time monitoring of motor heating conditions. Ensure effective protection of the repeated starting of the motor overheating condition continuous run.

Device provide 12 inverse time protection curves; user can select suitable curve for different motor working condition.

Inverse-time formula

$$t = \frac{K}{\left(\frac{I}{I_e}\right)^2 - 1}$$

- t** Operating inverse time
- I** Motor working current value
- I<sub>e</sub>** Motor rated current
- K** K factor curve need set

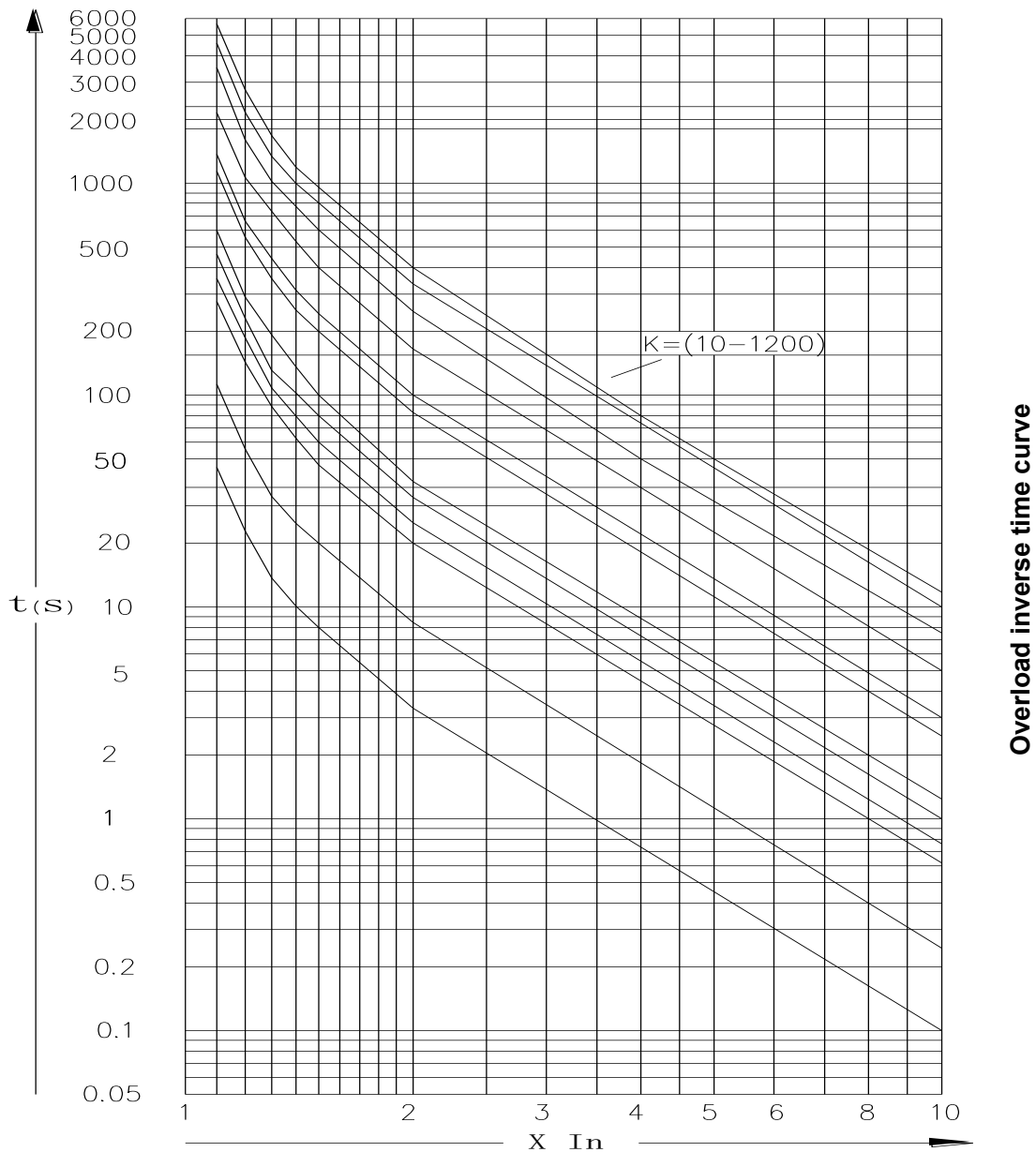

Typical trip time in different K factor and protection class

K factor	Class	I/le = 1.0	I/le 1.2	I/le 1.5	I/le 7.2
125	10	Without trip in 2h	Trip in 1h	$T_p \leq 2\text{min}$	$2\text{s} < T_p \leq 10\text{s}$
250, 300	10			$T_p \leq 4\text{min}$	$4\text{s} < T_p \leq 10\text{s}$
500	20			$T_p \leq 8\text{min}$	$6\text{s} < T_p \leq 20\text{s}$
750	30			$T_p \leq 12\text{min}$	$9\text{s} < T_p \leq 30\text{s}$

Overload inverse time curve quick select chart (time unit: sec)

K / I/le	10	25	60	75	100	125	250	300	500	750	1000	1200
1.1	47.62	119.05	285.71	357.14	476.19	595.24	1190.48	1428.57	2380.95	3571.43	4761.90	5714.28
1.2	22.73	56.82	136.36	170.45	227.27	284.09	568.18	681.82	1136.36	1704.55	2272.73	2727.27

1.3	14.49	36.23	86.96	108.70	144.93	181.16	362.32	434.78	724.64	1086.96	1449.28	1739.13
1.4	10.42	26.04	62.50	78.13	104.17	130.21	260.42	312.50	520.83	781.25	1041.67	1250.00
1.5	8.00	20.00	48.00	60.00	80.00	100.00	200.00	240.00	400.00	600.00	800.00	960.00
2.0	3.33	8.33	20.00	25.00	33.33	41.67	83.33	100.00	166.67	250.00	333.33	400.00
2.5	1.90	4.76	11.43	14.29	19.05	23.81	47.62	57.14	95.24	142.86	190.48	228.57
3.0	1.25	3.13	7.50	9.38	12.50	15.63	31.25	37.50	62.50	93.75	125.00	150.00
3.5	0.89	2.22	5.33	6.67	8.89	11.11	22.22	26.67	44.44	66.67	88.89	106.67
4.0	0.67	1.67	4.00	5.00	6.67	8.33	16.67	20.00	33.33	50.00	66.67	80.00
4.5	0.52	1.30	3.12	3.90	5.19	6.49	12.99	15.58	25.97	38.96	51.95	62.34
5.0	0.42	1.04	2.50	3.13	4.17	5.21	10.42	12.50	20.83	31.25	41.67	50.00
5.5	0.34	0.85	2.05	2.56	3.42	4.27	8.55	10.26	17.09	25.64	34.19	41.03
6.0	0.29	0.71	1.71	2.14	2.86	3.57	7.14	8.57	14.29	21.43	28.57	34.29
6.5	0.24	0.61	1.45	1.82	2.42	3.03	6.06	7.27	12.12	18.18	24.24	29.09
7.0	0.21	0.52	1.25	1.56	2.08	2.60	5.21	6.25	10.42	15.63	20.83	25.00
7.2	0.20	0.49	1.18	1.48	1.97	2.46	4.92	5.90	9.83	14.75	19.67	23.60
7.5	0.18	0.45	1.09	1.36	1.81	2.26	4.52	5.43	9.05	13.57	18.10	21.72
8.0	0.16	0.40	0.95	1.19	1.59	1.98	3.97	4.76	7.94	11.90	15.87	19.05

Protect action	OFF / Alarm / Trig DO
K factor value	10 ~ 1200
Cool down timer <sup>(1)</sup>	1 ~ 1200 min
Overload reset method <sup>(2)</sup>	Auto reset / Force cooling

**(1) Cool down timer:**

After motor stop, the cool down timer countdown to simulated the motor cools to a safe state process; the definition of the cooling time is to reach steady state of ambient temperature (the maximum allowable temperature) when motor overload trip.

Typically, suggest cool down timer set “30 minutes” to let motor cooled completely.

**(2) Overload reset method:**

If protect action select [Trig DO], After relay tripped there have two ways reset motor to next working cycle (Standby status):

Automatic	Wait UTC < 15%, press  button to reset status directly
Manual	Wait UTC < 15% <b>AND</b> [Cool down timer] countdown to 0, press  button to reset status.

**Notes:**

1. If overload protection triggered after UTC > 15%, press **Stop** will invalid, HMI still show “Overload”; Must reset UTC to 0%, then press **Stop** to Standby status.
2. Press and hold  3 seconds can reset UTC to 0%.
3. Used thermal capacity (UTC) displayed on HMI (**See chapter 5.4**), or read from register 0x0D.



### **7.3- Jam in Running Protection (Stall)**

Protective action logic:

Motor measured current > Threshold set value

Protection mode	OFF/Alarm/Trip
Threshold	100 ~ 1000% I <sub>e</sub>
Trip delay	0.5 ~ 50.0 s

**Note:** Only valid in regular running period.

### **7.4- Jam in Starting Protection (Rotor locked)**

Protective action logic:

Motor measured current > Threshold set value

Protect action	OFF / Alarm / Trip
Threshold	100 ~ 1000% I <sub>e</sub>
Action delay	0.5 ~ 50.0 s

**Note:** Only valid in starting period.

### **7.5- Phase Failure Protection**

Protective action logic:

Any two phase current > 25% Rated current, **AND** third phase current < 12.5% Rated current,

Protect action	OFF / Alarm / Trig DO
Action delay	0.1 ~ 50.0 s

**Notes:** This protection will valid in both starting and running period.

### 7.6- Current Imbalance Protection

Current imbalance protection based on the maximum phase current imbalance to determine whether to start phase unbalance protection function. Current unbalance is calculated as follows:

$$I_{im} = \frac{|I_{max} - I_{avg}|}{I_{avg}} \times 100\% \quad \text{or} \quad I_{im} = \frac{|I_{min} - I_{avg}|}{I_{avg}} \times 100\%$$

$I_{im}$  Three-phase current imbalance

$I_{max}$  Maximum phase current in the real-time measurement of three-phase

$I_{min}$  Minimum phase current in the real-time measurement of three-phase

$I_{avg}$  Three-phase average current

**Notes:** When the three-phase average current ( $I_{avg}$ ) is less than the motor rated current ( $I_e$ ), in formula  $I_{avg} = I_e$

Protective action logic:

$I_{im} >$  Threshold set value

Protect action	OFF / Alarm / Trig DO
Threshold	5 ~ 60%
Action delay	0.1~ 50.0 s

### 7.7- Ground Fault Protection

Device have two ways for ground fault protection, Sampling from external zero-sequence CT (residential current sensor **see chapter 3**), or calculated from fundamental frequency component. Please set detect mode in HMI or in register 0x20A.

Protect action	OFF / Alarm / Trig DO
Threshold <sup>(1)</sup>	10 ~ 100% $I_r$
Action delay <sup>(2)</sup>	0.1 ~ 5.0 s

(1) Threshold related residential CT install position, ideal state to set the lower threshold values.

(2) In directly grounding system, should set shorter delay timer to avoid damage or electrical shock;

In resistance grounding system, residual current be limited within a safe range, can set longer delay timer.

### **7.8- Under Power Protection**

If motor load occurs abnormal mutations, such as belt break or pump idling, define this situation is under power.

Protective action logic:

Motor measured current < Threshold set value

Protect action	OFF / Alarm / Trig DO
Threshold	20 ~ 100%Ie
Trip delay	0.6 ~ 60.0s

**Notes:** Typically, under power protection set to alarm mode, to notice site staff to pay attention.

### **7.9- Over Temperature Protection**

Device accept 1pcs NTC or PTC sensor for temperature measurement, provide original resistance parameters value.

Protective action logic:

Measured resistor > Threshold set value

Protect action	OFF / Alarm / Trig DO
Probe type <sup>(1)</sup>	NTC / PTC
Threshold	0.1 ~ 30Kohm
Hysteresis	0.1 ~ 30Kohm

(1) Probe type can select in HMI or in register 0x319.

### **7.10- Short Circuit Protection**

The protection is performed when motor occurred incorrectly wiring or line is damaged that caused short circuit.

Protect action	OFF / Alarm / Trig DO
Threshold	100 ~ 1000%Ie

Trip delay	0.1 ~ 50.0s
------------	-------------

**Notes:** suggest set threshold in large value, and short trip delay time. Set protect threshold = Contactor trip threshold (0x308). CB will trip priority than contactor.

### 7.11- Over Voltage Protection

Protective action logic:

Any of the three phase voltage > Threshold set value

Protect action	OFF / Alarm / Trig DO
Threshold	105 ~ 150% Ue
Trip delay	0.1 ~ 50.0s

**Notes:** This protection will valid in both starting and running period.

### 7.12- Under Voltage Protection

Protective action logic:

Any of the three phase voltage < Threshold set value

Protect action	OFF / Alarm / Trig DO
Threshold	50 ~95% Ue
Trip delay	0.1 ~ 50.0s

**Notes:** This protection will valid in both starting and running period. If enabled restart function (chapter 7.16), under voltage protection will automatically disable.

Enable under voltage protection can open Auto Restart function, this function used in some special application scenarios, by ignoring the under voltage protection caused by system voltage loss, let motor can be automatically restarted after the voltage recovered.

Voltage loss threshold	50% ~ 100%Ue; Set "0" to disable this function Default 80%Ue	Register 0x20C
Voltage recovered threshold	50% ~ 100%Ue; Set "0" to disable this function Default 80%Ue	Register 0x20D

Voltage loss timer	0.1s ~ 60.0s Default 5.0s	Register 0x20E
Restart delay timer	0.1 ~ 60.0s Default 0.1s	Register 0x20F

**Notes:** Motor start mode set [Only protection], Auto restart function is invalid.

### **7.13- Abnormal Frequency Protection**

Protective action logic:

Frequency > Upper threshold set value **OR**

Frequency < Lower threshold set value

Protect action	OFF / Alarm / Trig DO
Upper threshold	50.00 ~ 55.00Hz
Lower threshold	45.00 ~ 50.00Hz
Trip delay	0.1 ~ 50.0s

**7.14- Abnormal Power Factor Protection**

Protective action logic:

Power factor < Threshold set value

Protect action	OFF / Alarm / Trig DO
Threshold	20 ~95%
Trip delay	0.1 ~ 60.0s

**7.15.- tE Protection**

The tE protection function used for increased safety type motor(IEC-60079-7), it valid in both starting and running period. tE time protection fault must be reset manually. It cannot be valid with overload protection (**chapter 7.1**) at the same time.

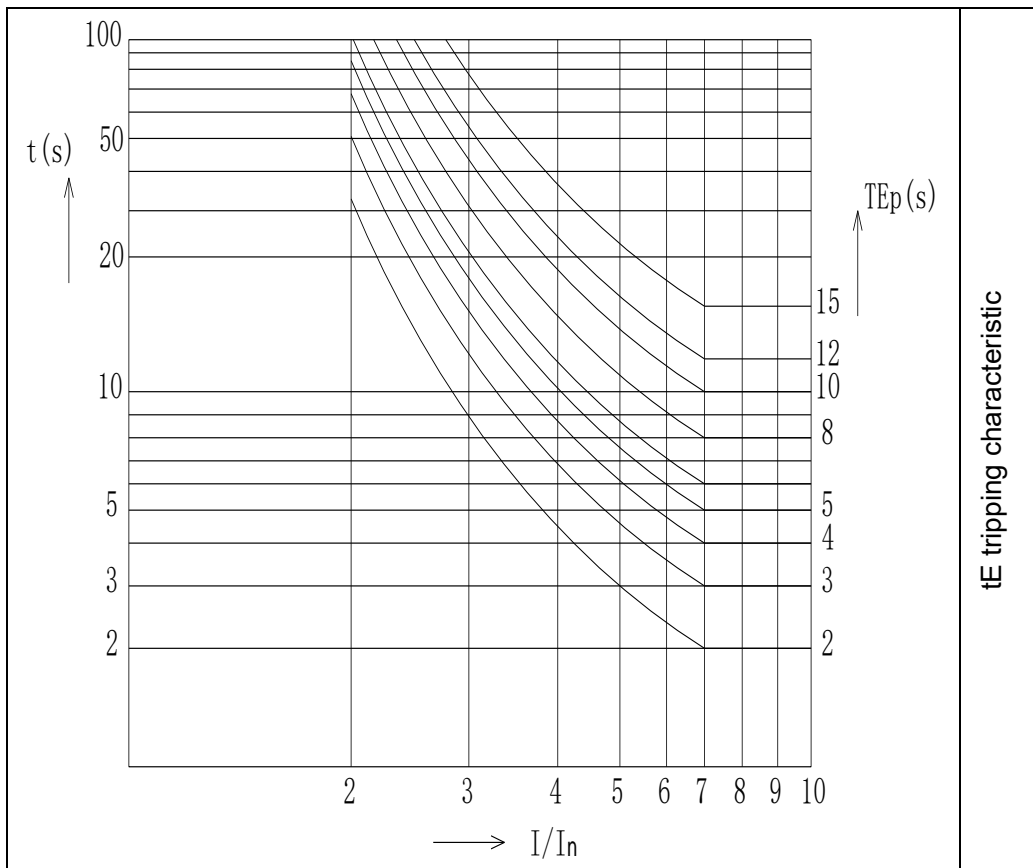

**Note:** To ensure that the regular overload protection act before tE trap time, we suggest choose lower inverse time curve in overload protection, typically less 15%.

Protect action	OFF / Alarm / Trig DO
Trip setting value tEp <sup>(1)</sup>	0.1 ~ 15.0 s

(1) Real trip delay value = Set tEp \* tEp[1.0s]

Example: Set tEp = 5, I/le=3.4

Trip delay timer = 15.4sec

tEp setting value quick select chart (time unit: sec)

I/le \ tEp	1.0(s)	4.0(s)	4.3(s)	4.6(s)	5.0(s)	5.5(s)	6.0(s)	15.0(s)
3.00	4.00	16.00	17.20	18.40	20.00	22.00	24.00	60.00
3.20	3.48	13.92	14.96	16.01	17.40	19.14	20.88	52.20
3.40	3.08	12.32	13.24	14.17	15.40	16.94	18.48	46.20
3.60	2.76	11.04	11.87	12.70	13.80	15.18	16.56	41.40
3.80	2.50	10.00	10.75	11.50	12.50	13.75	15.00	37.50
4.00	2.29	9.16	9.85	10.53	11.45	12.60	13.74	34.35
4.20	2.11	8.44	9.07	9.71	10.55	11.61	12.66	31.65
4.40	1.95	7.80	8.39	8.97	9.75	10.73	11.70	29.25
4.60	1.82	7.28	7.83	8.37	9.10	10.01	10.92	27.30
4.80	1.70	6.80	7.31	7.82	8.50	9.35	10.20	25.50
5.00	1.60	6.40	6.88	7.36	8.00	8.80	9.60	24.00
5.20	1.51	6.04	6.49	6.95	7.55	8.31	9.06	22.65
5.40	1.43	5.72	6.15	6.58	7.15	7.87	8.58	21.45
5.60	1.36	5.44	5.85	6.26	6.80	7.48	8.16	20.40
5.80	1.29	5.16	5.55	5.93	6.45	7.10	7.74	19.35
6.00	1.23	4.92	5.29	5.66	6.15	6.77	7.38	18.45
6.20	1.18	4.72	5.07	5.43	5.90	6.49	7.08	17.70
6.40	1.13	4.52	4.86	5.20	5.65	6.22	6.78	16.95
6.60	1.08	4.32	4.64	4.97	5.40	5.94	6.48	16.20
6.80	1.04	4.16	4.47	4.78	5.20	5.72	6.24	15.60
7.00	1.00	4.00	4.30	4.60	5.00	5.50	6.00	15.00
8.00	1.00	4.00	4.30	4.60	5.00	5.50	6.00	15.00

## 8- MOTOR START MODE INTRODUCTION

### 8.1.- Only protection mode

Terminal	Description	
DI1	Universal signal input	<p>1. After device powered ON, DO1 act, enters <b>[Standby]</b> state, HMI show "Full voltage"</p> <p>If wiring is wrong, HMI show "Wring Error", and failure alarm relay DO3 closed;</p> <p>If wiring is correct, enters <b>[Standby]</b> state, HMI show "Full voltage".</p> <p>2. When press external start button (SW2), KM loops picks up and latched. Motor powered up enter <b>[Starting]</b> period:</p> <p>In <b>[Starting]</b> period, "Start" light ON, HMI show "Starting";</p> <p>After Starting period, "Start" light OFF, "Runs" light ON, HMI show "Running".</p> <p>3. When press external stop button (SW1), <b>OR</b> there have protection tripping action:</p> <p>DO1 released, KM opened, motor stopped and in <b>[Cooling]</b> period, used thermal capacity (UTC) drops.</p> <p>4. After UTC&lt;15%, enters <b>[Standby]</b> state, HMI show "Full voltage".</p>
DI2	Universal signal input	
DI3	DI3 closed for HMI panel control; DI3 opened for external control	
DI4	External "Start" switch status	
DI5	Universal signal input	
DI6	Universal signal input	
DI7	Universal signal input	
DO1	To contractor (KM)	
DO2	/	
DO3	Motor failure alarm output	
DO4	To trip CB (QF)	

#### Notes:

- Control unit build in protect CT, Sampling CT in drawing:  
Motor rated current < 100A, power line can directly cross through the sampling core on control unit body.  
Motor rated current > 100A, need external .../5A protect CT, external CT secondary wire cross through the sampling core on control unit body. (need configuration in HMI or register 0x201, 0x202)
- If protector detect failure protect current > Contactor breaking current, there will judgment short circuit protection (**See chapter 7.10**). DO1 will keep closed until DO4 act and CB tripped (QF), after delay timer then can act DO1 to disconnect contactor (KM).
- In failure tripping, must use "Reset" switch looped to DI4 or "Reset" button on HMI to erase failure alarm then DO1 can act again to enter **[Standby]** state.



Typical wiring

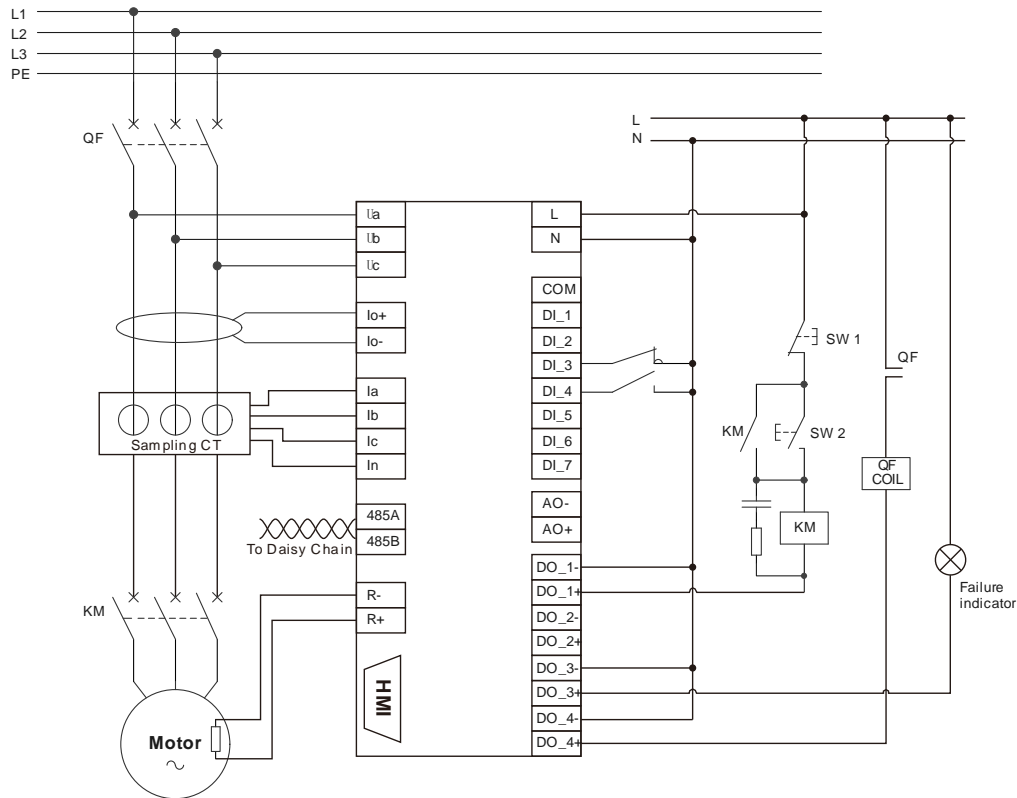

**Notes:** If enable auto restart function (**See chapter 7.16**), must connect DO2 for restart trip:

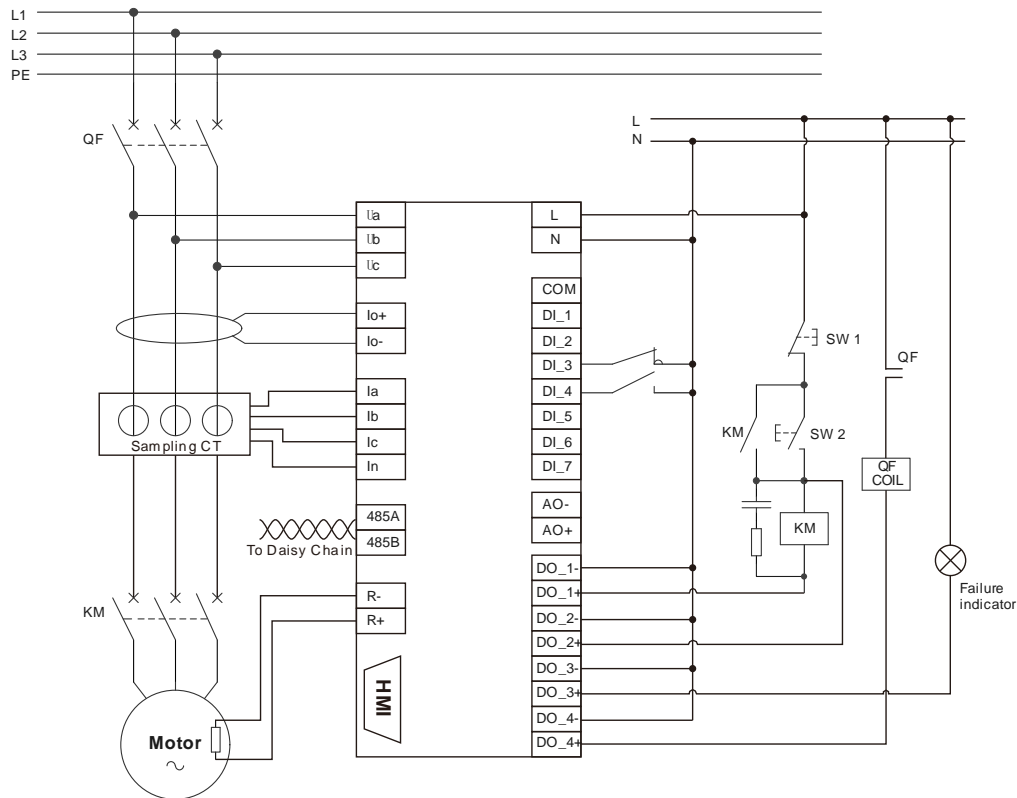

## 8.2.- Full voltage start mode

Terminal	Description	
DI1	Contactor (KM) status	<p>1. After device powered ON, detect contactor (KM) state: If wiring is wrong, HMI show "Wring Error", and failure alarm relay DO3 closed; If wiring is correct, enters <b>[Standby]</b> state, HMI show "Full voltage".</p> <p>2. When device received "Motor Start" signal, DO1 will act, then trig KM closed, motor powered up enter <b>[Starting]</b> period: In <b>[Starting]</b> period, "Start" light ON, HMI show "Starting"; After Starting period, "Start" light OFF, "Runs" light ON, HMI show "Running".</p> <p>3. When device received "Motor Stop" signal, <b>OR</b> there have protection tripping action: DO1 released, KM will open, motor stopped and in <b>[Cooling]</b> period, thermal capacity (UTC) drops.</p> <p>4. After UTC&lt;15%, enters <b>[Standby]</b> state, HMI show "Full voltage".</p> <p><b>Notes:</b> In failure tripping, must use "Reset" switch looped to DI4 or "Reset" button on HMI to erase failure alarm.</p>
DI2	Circuit Breaker (QF) status	
DI3	DI3 closed for HMI panel control; DI3 opened for external control	
DI4	External "Reset" switch status	
DI5	External "Start" switch status	
DI6	External "Stop" switch status	
DI7	Universal signal input	
DO1	To contractor (KM)	
DO2	/	
DO3	Motor failure alarm output	
DO4	To trip CB (QF)	

### Typical wiring

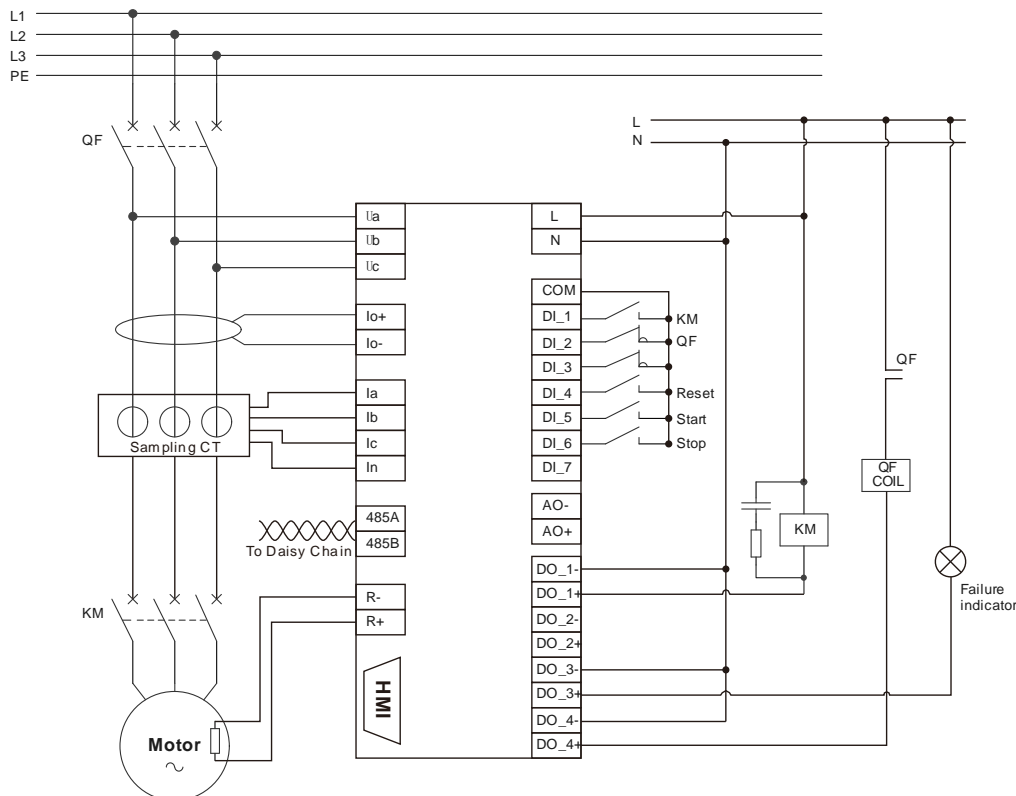

### 8.3.- Forward and reverse start mode

Terminal	Description	
DI1	Contactora (KM1) status	<p>1. After device powered ON, detect contactora (KM1) state:</p> <p>If wiring is wrong, HMI show "Wring Error", and failure alarm relay DO3 closed;</p> <p>If wiring is correct, enters <b>[Standby]</b> state, HMI show "Forward / Reverse".</p> <p>2.A. When device received "Motor Start A" signal, DO1 will act, then trig KM1 closed. Motor powered up enter <b>[Starting]</b> period, "Start" light ON, HMI show "Forward Starting";</p> <p>After Starting timer (0x32F) count down to 0, Motor enter normal runs status, "Start" light OFF, "Runs" light ON, HMI show "Running".</p> <p>2.B. When device received "Motor Start B" signal, DO2 will act, then trig KM2 closed. Motor powered up enter <b>[Starting]</b> period, "Start" light ON, HMI show "Reverse Starting";</p> <p>After Starting timer (0x32F) count down to 0, Motor enter normal runs status, "Start" light OFF, "Runs" light ON, HMI show "Running".</p>
DI2	Circuit Breaker (QF) status	
DI3	DI3 closed for HMI panel control; DI3 opened for external control	
DI4	External "Reset" switch status	
DI5	External "Start A" switch status	
DI6	External "Stop" switch status	
DI7	External "Start B" switch status	
DO1	To contractor (KM1)	<p>3. When device received "Motor Stop" signal, <b>OR</b> there have protection tripping action. DO1 or DO2 released, KM1 or KM3 will opened, motor stopped and in <b>[Cooling]</b> period, used thermal capacity (UTC) drops.</p> <p>4. After UTC&lt;15%, enters <b>[Standby]</b> state, HMI show "Forward / Reverse".</p>
DO2	To contractor (KM2)	
DO3	Motor failure alarm output	
DO4	To trip CB (QF)	

#### Typical wiring

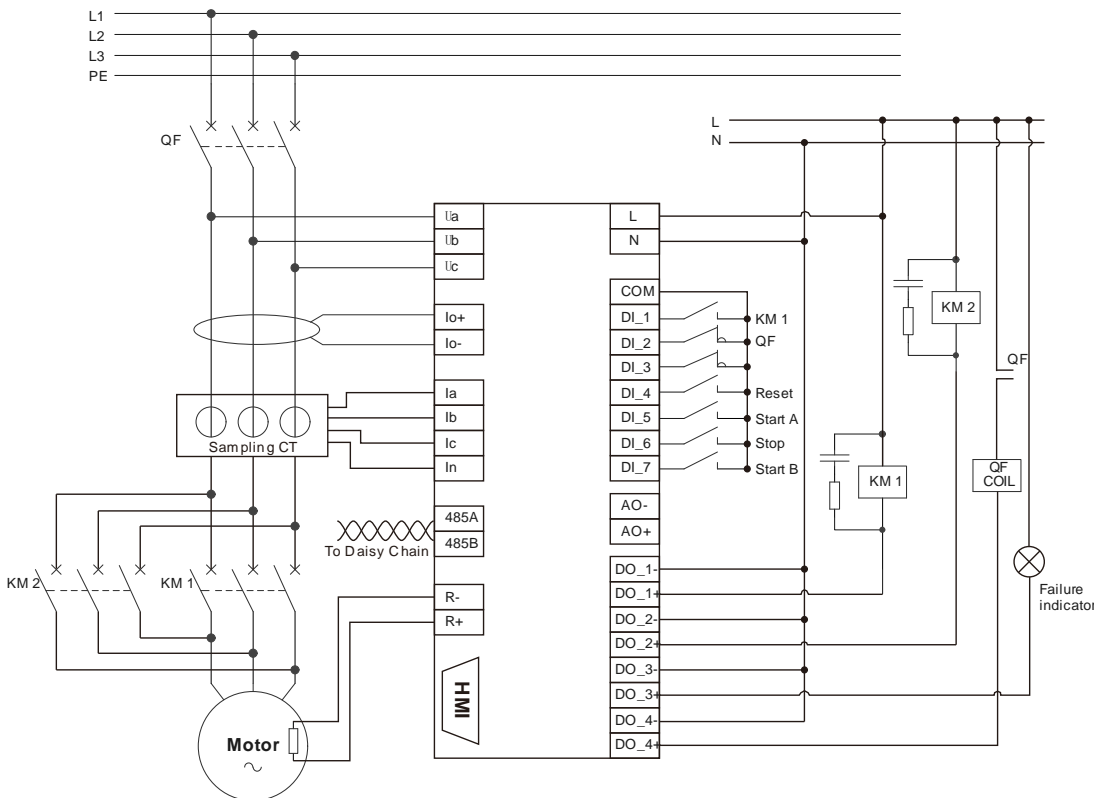

### 8.4.- Two-Winding start mode

Terminal	Description	
DI1	Contactor (KM1) status	<p>1. After device powered ON, detect contactor (KM1) state:</p> <p>If wiring is wrong, HMI show "Wring Error", and failure alarm relay DO3 closed;</p> <p>If wiring is correct, enters <b>[Standby]</b> state, HMI show " Two-Winding".</p> <p>2.A. When device received "Motor Start A" signal, DO1 will act, then trig KM1 closed. Motor powered up enter <b>[Starting]</b> period, "Start" light ON, HMI show "Low Starting";</p> <p>After Starting timer (0x32F) count down to 0, Motor enter normal runs status, "Start" light OFF, "Runs" light ON, HMI show "Running".</p> <p>2.B. When device received "Motor Start B" signal, DO2 will act, then trig KM2 closed. Motor powered up enter <b>[Starting]</b> period, "Start" light ON, HMI show "High Starting";</p> <p>After Starting timer (0x32F) count down to 0, Motor enter normal runs status, "Start" light OFF, "Runs" light ON, HMI show "Running".</p> <p>3. When device received "Motor Stop" signal, <b>OR</b> there have protection tripping action. DO1 or DO2 released, KM1 or KM3 will opened, motor stopped and in <b>[Cooling]</b> period, used thermal capacity (UTC) drops.</p> <p>4. After UTC&lt;15%, enters <b>[Standby]</b> state, HMI show "Two-Winding".</p>
DI2	Circuit Breaker (QF) status	
DI3	DI3 closed for HMI panel control; DI3 opened for external control	
DI4	External "Reset" switch status	
DI5	External "Start A" switch status	
DI6	External "Stop" switch status	
DI7	External "Start B" switch status	
DO1	To contractor (KM1)	
DO2	To contractor (KM2)	
DO3	Motor failure alarm output	
DO4	To trip CB (QF)	

#### Typical wiring

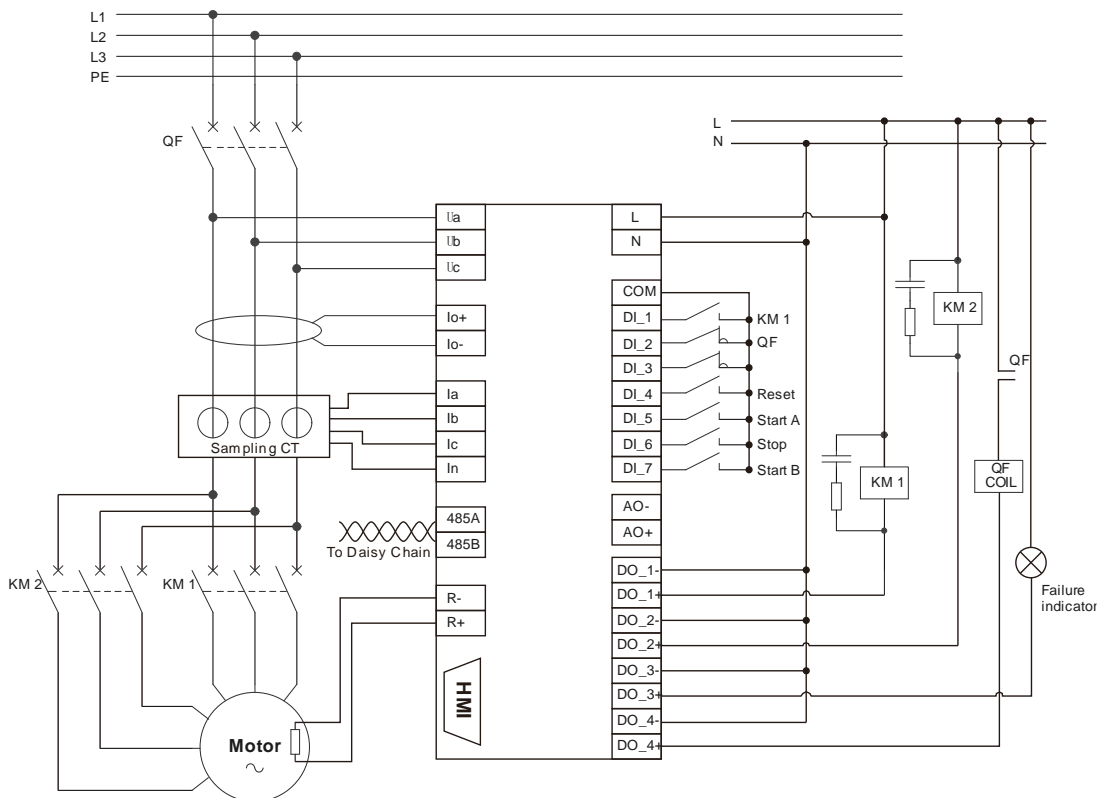

### 8.5.- Wye-Delta Transition mode

Terminal	Description	
DI1	Contactor (KM1) status	<p>1. After device powered ON, detect contactor (KM1) state: If wiring is wrong, HMI show "Wring Error", and failure alarm relay DO3 closed;</p> <p>If wiring is correct, enters <b>[Standby]</b> state, HMI show " Wye-Delta".</p>
DI2	Circuit Breaker (QF) status	
DI3	DI3 closed for HMI panel control; DI3 opened for external control	
DI4	External "Reset" switch status	
DI5	External "Start" switch status	
DI6	External "Stop" switch status	
DI7	Universal signal input	
DO1	To protect contractor (Relay A)	<p>2. When device received "Motor Start" signal, DO1 will act, then trig KM1, KM3 closed, motor powered up enter <b>[Starting]</b> period, "Start" light ON, HMI show "Starting";</p> <p>3. After Starting timer (0x32F) count down to 0, DO1 released, DO2 act, trig KM2, KM3 closed. Motor in normal runs status. "Start" light OFF, "Runs" light ON, HMI show "Running".</p> <p>4. When device received "Motor Stop" signal, <b>OR</b> there have protection tripping action: DO2 released, KM2, KM3 will opened, motor stopped and in <b>[Cooling]</b> period, used thermal capacity (UTC) drops.</p> <p>5. After UTC&lt;15%, enters <b>[Standby]</b> state, HMI show "Wye-Delta".</p>
DO2	To protect contractor (Relay B)	
DO3	Motor failure alarm output	
DO4	To trip CB (QF)	

#### Typical wiring

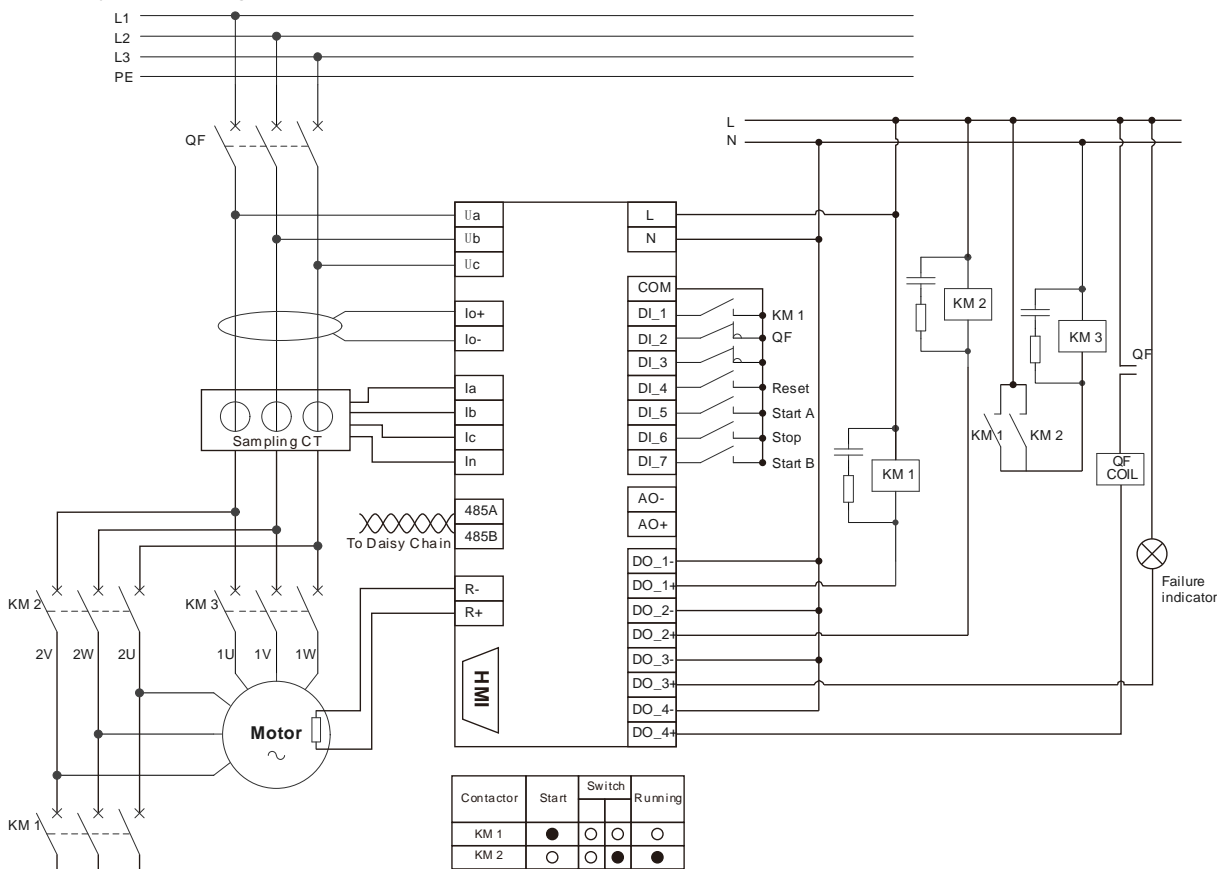

**8.6.- Autotransformer Closed Transition mode**

Terminal	Description	
DI1	Contactor (KM1) status	<p>1. After device powered ON, detect contactor (KM1) state: If wiring is wrong, HMI show "Wring Error", and failure alarm relay DO3 closed; If wiring is correct, enters <b>[Standby]</b> state, HMI show "Autotransformer".</p> <p>2. When device received "Motor Start" signal, DO1 will act, then trig KM1, KM3 closed, motor powered up enter <b>[Starting]</b> period, "Start" light ON, HMI show "Starting";</p> <p>3. After Starting timer (0x32F) count down to 0, DO1 released, DO2 act, trig KM2 closed. Motor enter normal runs status. "Start" light OFF, "Runs" light ON, HMI show "Running".</p> <p>4. When device received "Motor Stop" signal, <b>OR</b> there have protection tripping action: DO2 released, KM2 will opened, motor stopped and in <b>[Cooling]</b> period, used thermal capacity (UTC) drops.</p> <p>5. After UTC&lt;15%, enters <b>[Standby]</b> state, HMI show "Autotransformer".</p>
DI2	Circuit Breaker (QF) status	
DI3	DI3 closed for HMI panel control; DI3 opened for external control	
DI4	External "Reset" switch status	
DI5	External "Start" switch status	
DI6	External "Stop" switch status	
DI7	Universal signal input	
DO1	To protect contractor (Relay A)	
DO2	To protect contractor (Relay B)	
DO3	Motor failure alarm output	
DO4	To trip CB (QF)	

**Typical wiring**

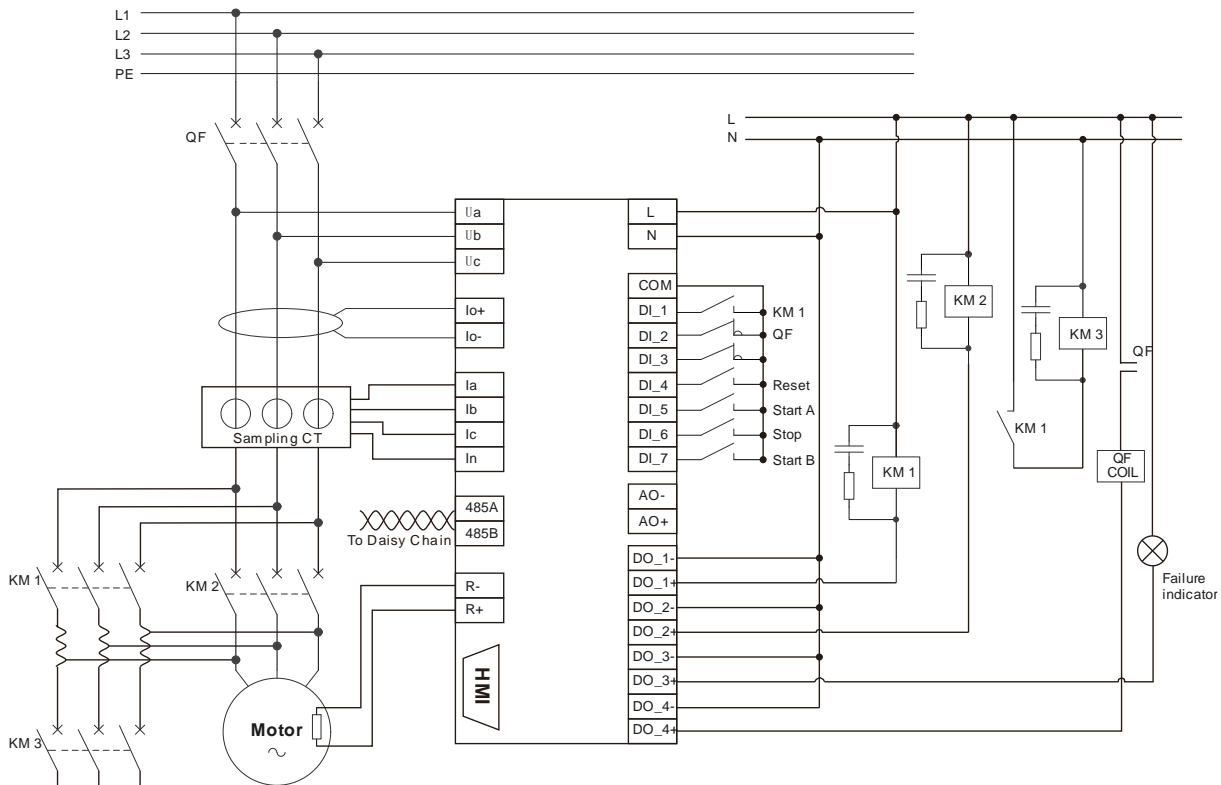

### 8.7- Circuit Breaker directly start mode

Terminal	Description	
DI1	Universal signal input	<p>1. After device powered ON, detect circuit breaker(QF) state: If wiring is wrong, HMI show "Wring Error", and failure alarm relay DO3 closed; If wiring is correct, enters <b>[Standby]</b> state, HMI show "CB Direct".</p> <p>2. When device received "Motor Start" signal, DO1 will act, then trig QF closed, motor powered up enter <b>[Starting]</b> period: In <b>[Starting]</b> period, "Start" light ON, HMI show "Starting"; After Starting period, "Start" light OFF, "Runs" light ON, HMI show "Running".</p> <p>3. When device received "Motor Stop" signal, <b>OR</b> there have protection tripping action: DO1 will released, QF will opened, motor stopped and in <b>[Cooling]</b> period, used thermal capacity (UTC) drops.</p> <p>4. After UTC&lt;15%, enters <b>[Standby]</b> state, HMI show "CB Direct".</p> <p><b>Notes:</b> In failure tripping, must use "Reset" switch looped to DI4 or "Reset" button on HMI to erase failure alarm.</p>
DI2	Circuit Breaker (QF) status	
DI3	DI3 closed for HMI panel control; DI3 opened for external control	
DI4	External "Reset" switch status	
DI5	External "Start" switch status	
DI6	External "Stop" switch status	
DI7	Universal signal input	
DO1	To contractor	
DO2	/	
DO3	Motor failure alarm output	
DO4	/	

#### Typical wiring

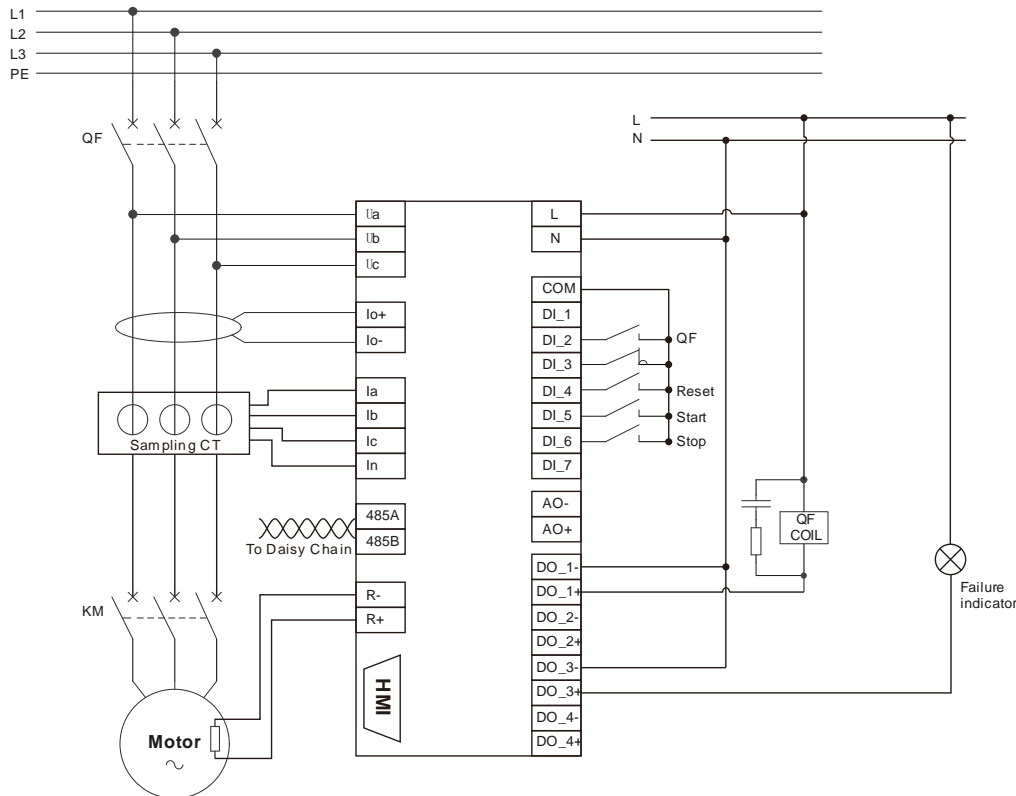

## 9. - SAFETY CONSIDERATIONS



All installation specification described at the previous chapters named:  
**INSTALLATION AND STARTUP, INSTALLATION MODES and SPECIFICATIONS.**

Note that with the instrument powered on, the terminals could be dangerous to touching and cover opening actions or elements removal may allow accessing dangerous parts. This instrument is factory-shipped at proper operation condition.

## 10. - MAINTENANCE

The EnergoM-PR240 series not require any special maintenance. No adjustment, maintenance or repairing action should be done when the instrument is open and powered on, should those actions are essential, high-qualified operators must perform them.

Before any adjustment, replacement, maintenance or repairing operation is carried out; the instrument must be disconnected from any power supply source.

When any protection failure is suspected to exist, the instrument must be immediately put out of service. The instrument's design allows a quick replacement in case of any failure.